

# OPERATOR'S MANUAL

# 81233X

SPECIFICATIONS, SERVICE KITS, GENERAL INFORMATION, TROUBLESHOOTING  
INCLUDE MANUALS: 87100X Lower Pump End (pn 876015), 842002 Air Motor (pn 876020) & S-1099 General Information Manual (pn 876018)

RELEASED: 9-1-99  
REVISED: 4-21-05  
(REV. E)

**6" AIR MOTOR**  
**23:1 RATIO**  
**6" STROKE**

## 81233X TWO BALL PUMP SERIES 300 SERIES STAINLESS STEEL



**READ THIS MANUAL CAREFULLY BEFORE INSTALLING,  
OPERATING OR SERVICING THIS EQUIPMENT.**

It is the responsibility of the employer to place this information in the hands of the operator. Keep for future reference.

### SERVICE KITS

- Use only genuine Bink's replacement parts to assure compatible pressure rating and longest service life.
- **861032** for repair of air motor section.
- **861000** for repair of lower pump section. Refer to the chart on page 2 for description of the pump.
- **861001** optional kit for repair of lower pump section.

### SPECIFICATIONS

<b>Model Series</b> (refer to option chart)	81233X
<b>Type</b>	Air Operated, Two Ball
<b>Ratio</b>	23:1
<b>Air Motor</b>	842002
<b>Motor Repair Kit</b>	861032
<b>Motor Diameter</b>	6" (15.2 cm)
<b>Stroke</b>	6" (15.2 cm)
<b>Air Inlet (female)</b>	1/2 - 14 N.P.T.F. - 1
<b>Air Exhaust (female)</b>	1-1/4 - 11-1/2 N.P.T.F. - 1
<b>Lower Pump End Series</b>	87100X
<b>Lower Pump Repair Kit</b>	86100X
<b>Material Inlet</b>	1 - 11-1/2 N.P.T.F. - 1 (female) & 2 - 11-1/2 P.T.F. spec. short (male)
<b>Material Outlet (female)</b>	1 - 11-1/2 N.P.T.F. - 1
<b>Weight</b>	46.2 lbs (21 kgs)

### PERFORMANCE

<b>Air Inlet Pressure Range</b>	30 - 150 p.s.i. (2.1 - 10.3 bar)
<b>Fluid Pressure Range</b>	690 - 3495 p.s.i. (47.6 - 241 bar)
<b>Maximum Rec'd Cycles / Minute</b>	60
<b>Displacement In<sup>3</sup> Per Cycle</b>	14.5
<b>Volume / Cycle</b>	8 oz. (238 ml)
<b>Cycles Per Gallon</b>	15.9
<b>Flow @ 60 Cycles / Minute</b>	3.7 g.p.m. (14.0 l.p.m.)
<b>Noise Level @ 60 p.s.i. - 40 cpm</b>	84.8 db(A) *

\* The pump sound pressure level has been updated to an Equivalent Continuous Sound Level (L<sub>Aeq</sub>) to meet the intent of ANSI S1. 13-1971, CAGI-PNEUROP S5.1 using four microphone locations.

### PUMP DATA

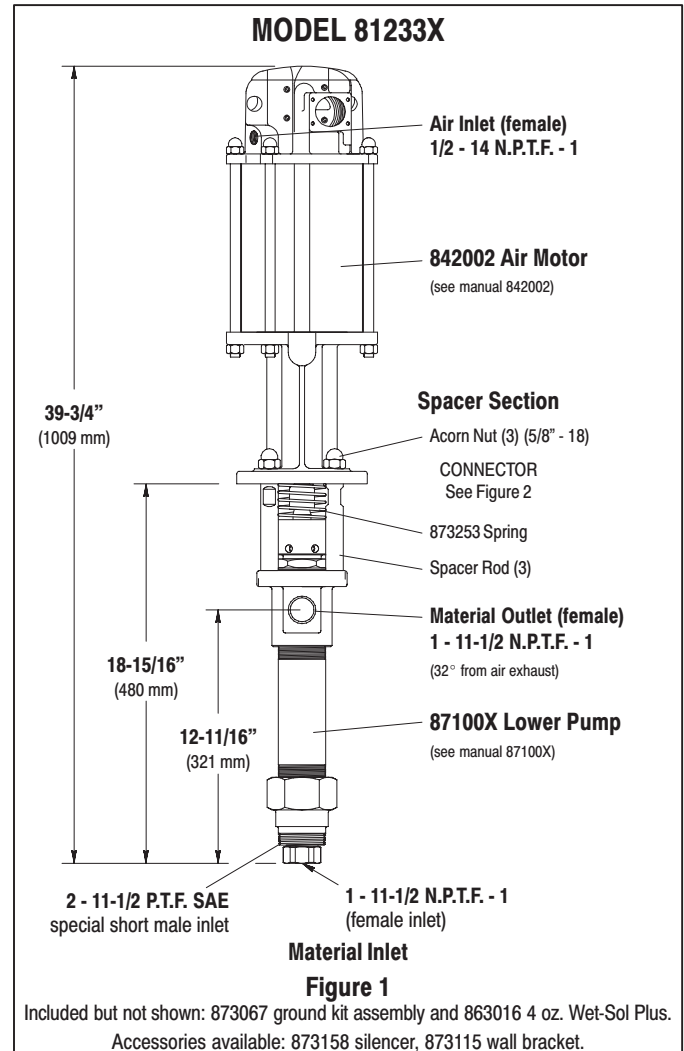

### IMPORTANT

**This is one of the four documents which support the pump. Replacement copies of these forms are available upon request.**

- 81233X Model Operator's Manual (pn 876031)
- General Information - Industrial Piston Pumps (pn 876018)
- 87100X Lower Pump End Operator's Manual (pn 876015)
- 842002 Air Motor Operator's Manual (pn 876020)

# BINKS®

North American Office  
Industrial Finishing  
195 Internationale Blvd  
Glendale Heights, IL 60139  
Tel. 630-237-5000 Fax 630-237-5011

International Office  
Industrial Finishing  
Ringwood Road, Bournemouth  
Dorset, BH11 9LH, England  
Tel. 0 1202 571111 Fax 0 1202 593883

# PUMP OPTION DESCRIPTION CHART

**81233 X**  
 PLUNGERTYPE

**PACKING MATERIAL**

UHMW-PE (upper and lower)  
 Optional Glassfilled Pather staggered (upper and lower)

**SPRING ARRANGEMENT**

Multiple wavespring

**PLUNGERTYPE**

0 Hard Stainless Steel with hard chrome plating  
 5 Hard Stainless Steel with ceramic coating

## GENERAL DESCRIPTION

**⚠ WARNING HAZARDOUS PRESSURE.** Do not exceed maximum operating pressure of 3495 p.s.i. (241 bar) at 150 p.s.i. (10.3 bar) inlet air pressure.

**PUMP RATIO X INLET PRESSURE TO PUMP MOTOR = MAXIMUM PUMP FLUID PRESSURE**

Pump ratio is an expression of the relationship between the pump motor area and the lower pump end area. EXAMPLE: When 150 p.s.i. (10.3 bar) inlet pressure is supplied to the motor of a 6:1 ratio pump it will develop a maximum of 900 p.s.i. (62.1 bar) fluid pressure (at no flow) - as the fluid control is opened, the flow rate will increase as the motor cycle rate increases to keep up with the demand.

**⚠ WARNING** Refer to general information sheet for additional safety precautions and important information.

- The Two-Ball pumps are primarily designed for the pumping of medium viscosity fluids. Stainless Steel construction offers compatibility with a wider range of fluids. The two-ball design provides better priming of the lower foot valve. The double acting feature is standard in all Bink's industrial pumps, material is delivered to the pump discharge outlet on both the up and down stroke.
- The motor is connected to the lower pump end by a spacer section. This allows for lubrication of the upper packing gland and prevents motor contamination because of normal wear and eventual leakage through the material packing gland. Be sure the solvent cup is adequately filled with lubricant to protect the upper packings and insure long service life.

## TROUBLE SHOOTING

Pump problems can occur in either the Air Motor section or the Lower Pump End section. Use these basic guidelines to help determine which section is affected.

**If the pump will not cycle.**

- Be certain to first check for non-pump problems including kinked, restrictive or plugged inlet/outlet hose or dispensing device. Depressurize the pump system and clean out any obstructions in the inlet/outlet material lines.
- Refer to the motor manual for troubleshooting if the pump does not cycle and/or air leaks from the air motor.

**If the pump cycles but does not deliver material.**

- Refer to the lower pump end manual for further troubleshooting.

## PUMP CONNECTION – UPPER / LOWER

**NOTE: All threads are right hand.**

1. Lay the pump assembly on a workbench.
2. Remove the three nuts from the three spacer rods (see figure 1).
3. Pull the air motor from the lower pump end until motor piston rods in the "down" position and lower pump end rods in "up" position.
4. Use ring pliers, slide the retaining ring up far enough to allow the sleeve to move upward and release the two connectors (see figure 2).

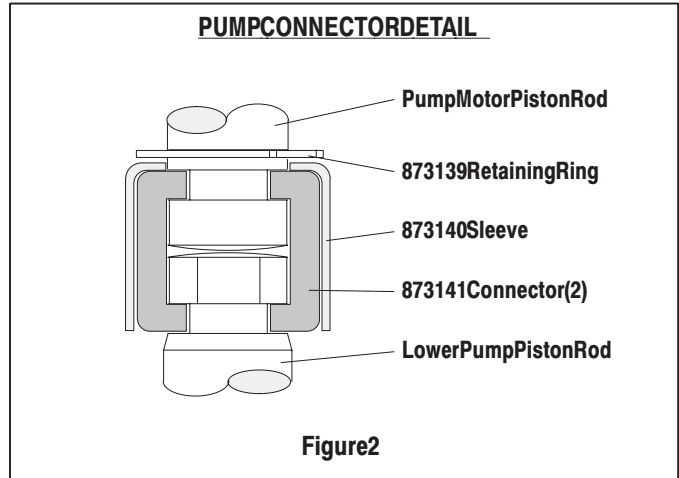

**REASSEMBLY**

1. Align the pump motor with the lower pump end.
2. Install the two connectors and retain with the sleeve, slide the retaining ring back into position.
3. Reinstall the spacer rods to the pump motor.
4. Bring the motor and lower pump together and retain with the three nuts.