



This manual contains important warnings and information.  
**READ AND KEEP FOR REFERENCE.**

INSTRUCTIONS

For use **ONLY** with the **GM 1030 TexSpray Gun**

**GASOLINE-POWERED SPRAYER WITH 3 GPM PUMP AND PNEUMATIC GUN CONTROL**

## GM 1030™ TexSpray

*1000 psi (7.0 MPa, 70 bar) Maximum Working Pressure (Absolute)*

*150 psi (1.0 MPa, 10 bar) Maximum Fluid Working Pressure (Recommended)*

The GM1030 TexSpray Sprayer, Gun and Hose Set are designed to work together. This unique combination of components is possible because of the unit's Easy Spray Control which ensures that no fluid can be trapped under pressure in the gun or hose. When used according to the instructions, the fluid pressure will not exceed the working pressure rating of the components.

### Model 231300, Series B

With one 50 ft (15 m) air and fluid hose set

Patents Pending

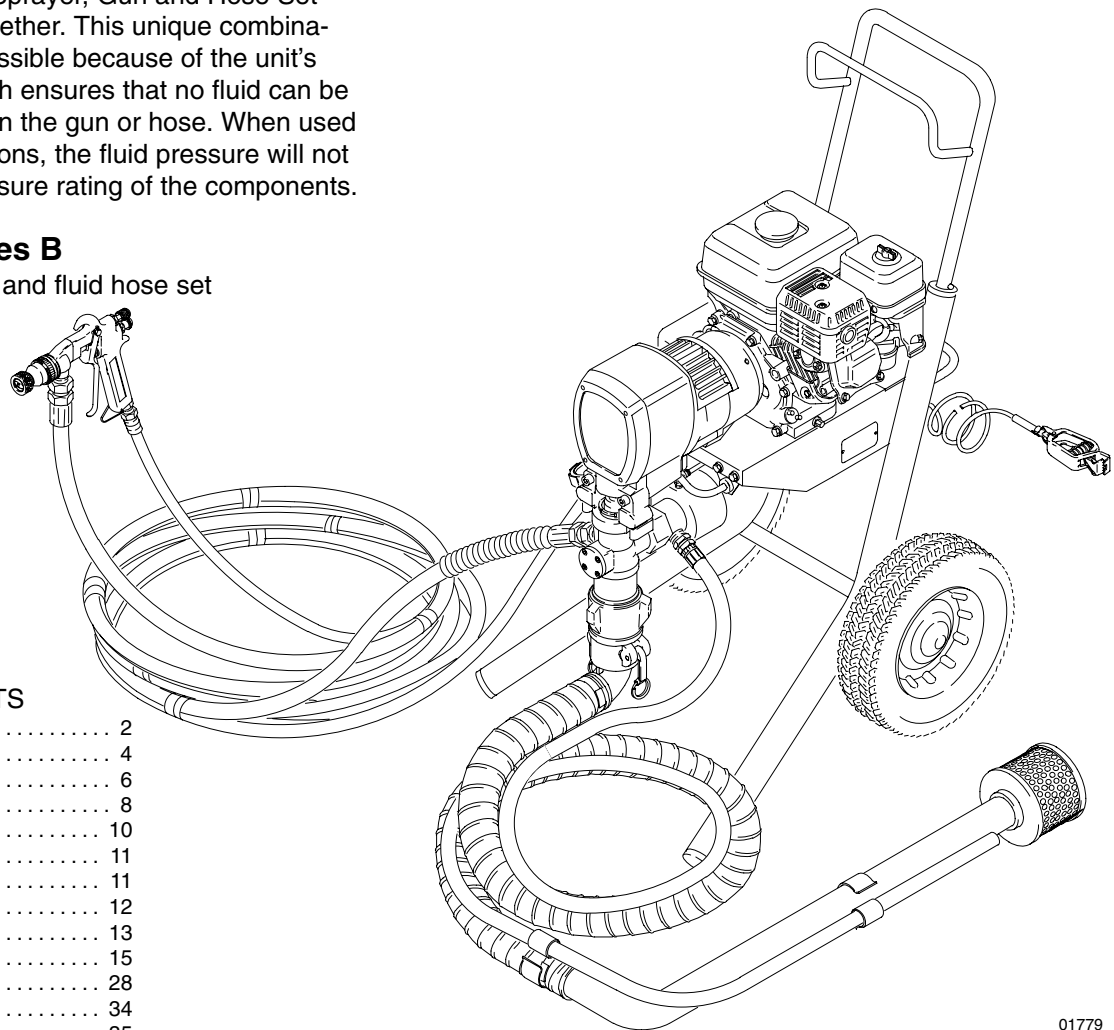

### TABLE OF CONTENTS

Warnings .....	2
Component Description .....	4
Setup .....	6
Startup .....	8
Flushing Guidelines .....	10
Helpful Hints .....	11
Fueling .....	11
Maintenance .....	12
Troubleshooting Guide .....	13
Repair .....	15
Parts .....	28
Accessories .....	34
Technical Data .....	35
Dimensions .....	35
Graco Phone Number .....	35
Warranty .....	36

01779

# Symbols

## Warning Symbol



This symbol alerts you to the possibility of serious injury or death if you do not follow the instructions.

## Caution Symbol



This symbol alerts you to the possibility of damage to or destruction of equipment if you do not follow the instructions.



INSTRUCTIONS

### EQUIPMENT MISUSE HAZARD

Equipment misuse can cause the equipment to rupture, malfunction or start unexpectedly and result in serious injury.

- This equipment is for professional use only.
- Read all instruction manuals, tags, and labels before operating the equipment.
- Use the equipment only for its intended purpose. If you are uncertain about the usage, call your Graco distributor.
- The GM 1030 TexSpray is intended for use outside and with texture materials at low application pressures. If you are using the sprayer for any other application, including the high pressure pump accessory, GM 3012, you must provide complete system grounding, as explained in manual 308127.
- The procedures in this manual are only for the GM1030 TexSpray when used with the 2 gpm or 3 gpm texture pump. If you use the 1.2 gpm GM 3012 high pressure paint pump, refer to the manual, 308127, supplied with it for specific information and warnings.
- The GM 1030 TexSpray Gun, 235490, is for use ONLY with the GM 1030 TexSpray, 231300 which is specially designed so that the fluid pressure of the gun will not exceed the working pressure rating of the components.
- Do not exceed the maximum working pressure of the lowest rated system component. This equipment has a **1000 psi (7.0 MPa, 70 bar) maximum working pressure**.
- Do not alter or modify this equipment. Use only genuine Graco parts and accessories.
- Check equipment daily. Repair or replace worn or damaged parts immediately.
- Do not lift pressurized equipment.
- Route the hoses away from the traffic areas, sharp edges, moving parts, and hot surfaces. Do not expose Graco hoses to temperatures above 180°F (82°C) or below -40°F (-40°C).
- Do not use the hoses to pull the equipment.
- The material hose must have a spring guard at the end which is installed at the outlet of the automatic pressure drain valve. The spring guard helps protect the hose from stress and strain which could cause the hose to rupture.
- Use fluids or solvents that are compatible with the equipment wetted parts. See the **Technical Data** section of all the equipment manuals. Read the fluid and solvent manufacturer's warnings.
- Do not use 1,1,1-trichloroethane, methylene chloride, other halogenated hydrocarbon solvents or fluids containing such solvents in this equipment, which contains aluminum and/or zinc parts. Such use could result in a serious chemical reaction, with the possibility of explosion, which could cause death, serious injury and/or substantial property damage.
- Comply with all applicable local, state and national fire, electrical and other safety regulations.
- Wear ear protection when operating this equipment. See sound levels in **Technical Data**.

# WARNING



## TOXIC FLUID HAZARD

Hazardous fluids or toxic fumes can cause a serious injury or death if the fluid is swallowed or splashed in the eyes or on the skin or if the fumes are inhaled.

- Know the specific hazards of the fluid you are using.
- Store hazardous fluid in an approved container. Dispose hazardous fluid according to all local, state and national guidelines.
- Wear appropriate clothing, gloves, eyewear and respirator.



## MOVING PARTS HAZARD

Moving parts or parts that start unexpectedly can pinch or amputate fingers or cause other serious injury.



- Keep clear of any moving parts, such as the connecting link and pin of the pump, when starting or operating or checking the equipment.
- When the GM 1030 Texture Sprayer is used with a 2 gpm or 3 gpm pump and the Easy Spray Control, the fluid pressure is relieved automatically when the gun trigger is released. To further reduce the risk of a serious injury, follow the **Pressure Relief Procedure** on page 8 when you are not spraying and before checking or adjusting the system.
- If you are using the 1.2 gpm (GM 3012) high pressure paint pump on the Texture Sprayer, follow the Pressure Relief Procedure in manual 308127.
- Be sure the pump's retaining spring is firmly and completely in the groove of the connecting link to prevent the pin from working loose due to vibration.
- Hold the engine starter rope as it recoils to prevent it hitting someone and causing injury, or jamming the rope in the recoil assembly.
- Shut off the engine and disconnect the spark plug before performing any checks or service to prevent the sprayer from starting unexpectedly.



## GASOLINE ENGINE HAZARD

The exhaust contains carbon monoxide, a poisonous, odorless and invisible gas which can cause serious illness and even death if inhaled. In addition, gasoline is extremely flammable and could cause a fire, explosion and serious injury under certain circumstances.



- Do not operate the engine in a closed building unless the engine exhaust is piped outside.
- Follow the **Fueling** procedures on page 11 carefully.



# Component Description

## Easy Spray Control

The Easy Spray Control (A) has a quick shut off and pressure relief feature so you get a soft start each time you trigger the gun, instead of a blast of unatomized material. See Fig. 1. The control has three modes:

- **SPRAY/FILL HOSE:** Triggering the gun sends an air signal to the Easy Spray Control that closes the Automatic Pressure Drain Valve and starts the pump which fills the material hose. When the gun trigger is released, the Automatic Pressure Drain Valve opens and relieves the system pressure into the supply container. This automatic pressure relief and the special TexSpray hoses and pump design eliminates blasts of material when the gun is triggered and eliminates “spray pulsing” to ensure consistent atomization.
- **OFF/RELIEVE PRESSURE:** Puts the sprayer in neutral/relieve pressure – neither the pump nor the gun will operate and there is no material pressure in the pump, hose or gun.
- **PRIME PUMP:** The Automatic Pressure Drain Valve remains open so material circulates through the pump and back to the drum through the drain hose.

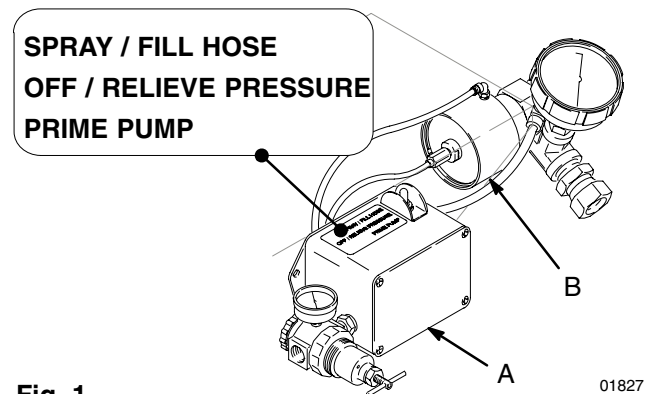

Fig. 1 01827

## Automatic Pressure Drain Valve

The pressure drain valve (B) automatically relieves system pressure when you release the gun trigger and the valve also stops the pump. See Fig. 1.

## TexSpray Gun, 235490

**⚠ WARNING**

**EQUIPMENT MISUSE HAZARD**  
The TexSpray Gun 235490 is for use only with the GM 1030 TexSpray 231300 which is specially designed so that the fluid pressure of the gun will not exceed the working pressure rating of the components. The maximum fluid working pressure of the GM 1030 TexSpray is 1000 psi (7 MPa, 70 bar), but the recommended maximum is 150 psi (1 MPa, 10 bar).

INSTRUCTIONS

The operator controls the air flow at the gun. During priming, turn the gun’s Air Control Valve (C) in fully to prevent air from mixing with the fluid, which allows you to check and adjust the fluid flow accurately. (When this valve is closed the air exits the rear of the gun.) During operation, open the Air Control Valve to introduce air at the correct volume for the desired spray pattern. The gun also has a trigger bail (D) to reduce operator fatigue when spraying large surfaces. See Fig. 2.

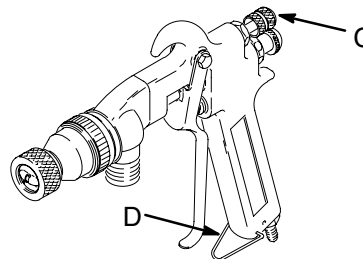

Fig. 2 01808

## Optional Flow Restrictor, 190109

This accessory (E) restricts the flow of fluid to the gun when using thin materials. Install as shown in Fig. 3.

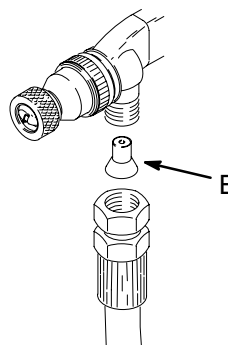

Fig. 3 04628

## TexSpray Hoses

**⚠ CAUTION**

Use only the genuine Graco hoses designed for use with this sprayer. Using other hoses will damage the Easy Spray Control.

## Optional 2 gpm Pump Kit, 235965

This accessory kit (not shown) directly replaces the standard TexSpray three gpm pump. Use it when spraying smooth and fine textures where lower volume is important for better control. The accessory operates in the 1/4 to 2 gpm range.

# Component Description

## GM3012 High Pressure Paint Pump Kit, 224524

Quickly convert the GM1030 TexSpray sprayer to an airless sprayer to spray primer, sealer, smooth elastomers as well as architectural paints, acrylics, urethanes and bonding adhesives at up to 1.25 gpm (4.75 lpm) with 0.035 inch maximum size spray tip at 3000 psi (21.0 MPa, 210 bar) Maximum Working Pressure. This accessory includes a high pressure pump, fluid filter, optional filter screen, drain valve and pressure control. See Fig. 4.

The system requires an airless spray gun and tip guard and an airless spray hose with spring guards on both ends. These accessories must be rated for at least 3000 psi (21.0 MPa, 210 bar) working pressure.

Switching the pumps takes about 5 minutes. Refer to the manual 308127, supplied with the kit, for specific warnings, setup, operating and repair procedures.

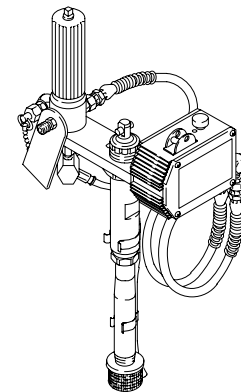

Fig. 4

0416

## Compressor Requirements

**NOTE:** This sprayer will not operate without an external air compressor.

Air compressor range: 5 scfm to 35 scfm, 40 to 100 psi (0.2–0.76 MPa, 2 to 7.6 bar)

Material	2 gpm Desired Fluid Flow		3 gpm Desired Fluid Flow	
	Air Requirements*	Minimum Compressor Size	Air Requirements*	Minimum Compressor Size
Elastomerics (textured)	25 scfm at 90 psi (0.7 m <sup>3</sup> /min at 0.63 MPa, 6.3 bar)	15 HP	30 scfm at 90 psi (0.84 m <sup>3</sup> /min at 0.63 MPa, 6.3 bar)	18 HP
Simulated Accoustical	15 scfm at 60 psi (0.42 m <sup>3</sup> /min at 0.42 MPa, 4.2 bar)	8 HP	20 scfm at 60 psi (0.56 m <sup>3</sup> /min at 0.42 MPa, 4.2 bar)	10 HP
Splatter Coat and Knockdown	10 scfm at 40 psi (0.28 m <sup>3</sup> /min at 0.28 MPa, 2.8 bar)	5 HP	15 scfm at 40 psi (0.42 m <sup>3</sup> /min at 0.28 MPa, 2.8 bar)	15 HP
Orange Peel	15 scfm at 60 psi (0.42 m <sup>3</sup> /min at 0.42 MPa, 4.2 bar)	8 HP	20 scfm at 60 psi (0.56 m <sup>3</sup> /min at 0.42 MPa, 4.2 bar)	10 HP

\* Material, temperature and volume affect the cfm needed to properly atomize the material.

## Fluid Nozzle and Spray Disc Selection

Three spray discs and nozzles are supplied with the sprayer. The nozzles are numbered 1, 2 or 3 – the larger the number the more scfm is required. These parts can be interchanged to produce a pattern suitable for each job. Refer to Steps 7 and 8 on page 9 to fine tune the spray pattern.

Material	Fluid Nozzle	Spray Discs (by aggregate size)			
		Fine	Medium	Coarse	Extra Coarse
Elastomerics	#3	1/8 inch	1/4 inch	1/4 – 3/8 inch	3/8 inch
Simulated Accoustical	#2	1/8 inch	1/4 inch	1/4 – 3/8 inch	3/8 inch
Splatter Coat* and Knockdown	#1	1/4 – 3/8 inch	n/a	n/a	n/a
Orange Peel	#2	1/8 – 1/4 inch	n/a	n/a	n/a

\* When spraying interior splatter coat with heavy (unthinned or slightly thinned) drywall mud and the desired flow rate is 1 gpm or less, we recommend using the accessory 2 gpm pump, 235965.

# Setup

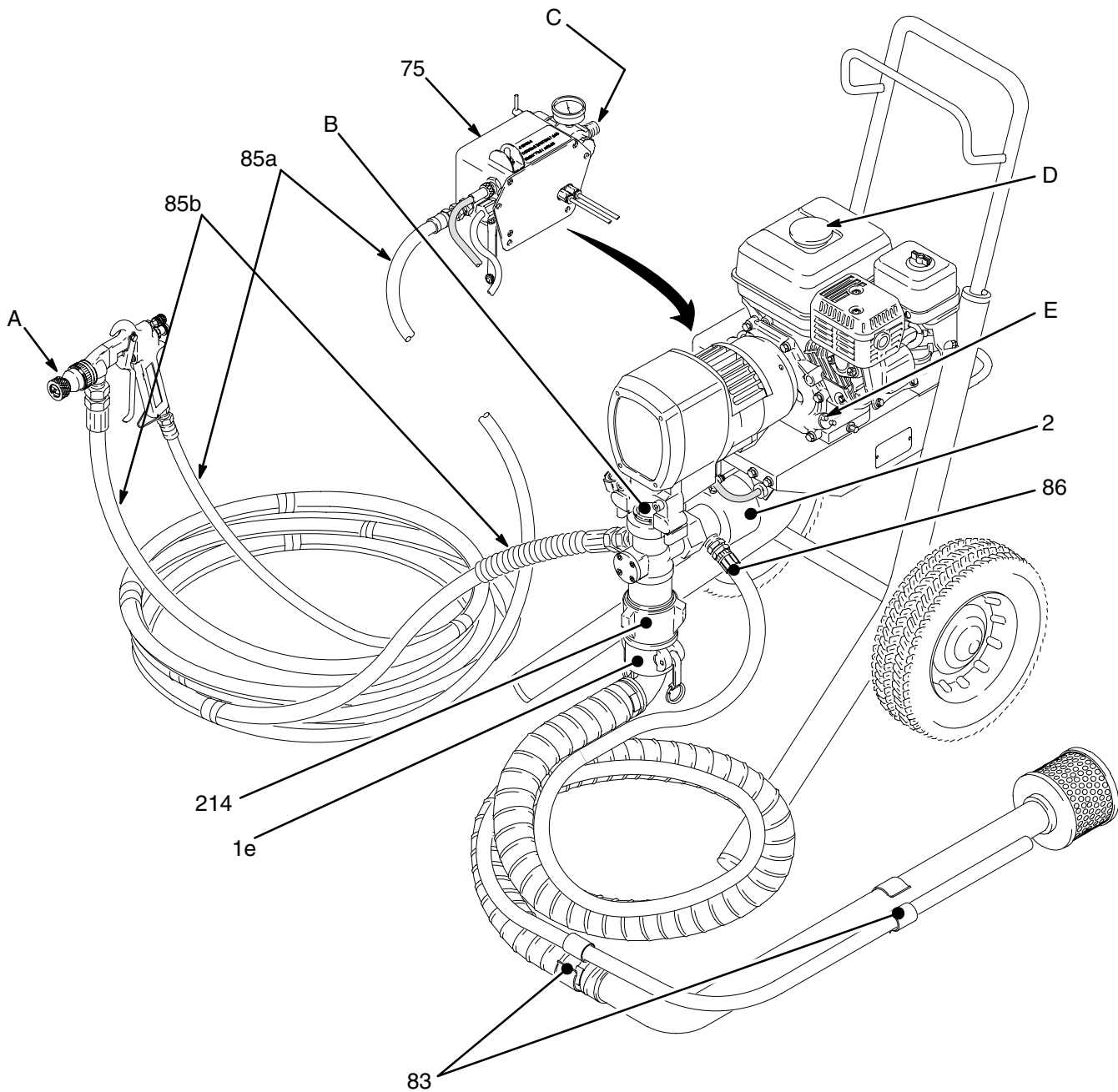

Fig. 5

01780

## ⚠ WARNING



INSTRUCTIONS

### EQUIPMENT MISUSE HAZARD

These procedures are only for this sprayer when used with the 2 gpm or 3 gpm texture pump. If you use the 1.2 gpm GM 3012 high pressure paint pump, refer to the manual supplied with it for specific information and warnings to reduce the risk of a serious injury.

**NOTE:** Refer to Fig. 5 unless otherwise indicated.

1. Read and follow the **WARNING** on pages 2 and 3 to help you to operate the system safely.
2. Read the **Component Description** on pages 4 and 5 to familiarize yourself with the features of this sprayer and to select a spray disc and nozzle combination.

# Setup

3. Connect the spring guard end of the 50 foot (15 m) material hose (85b) to the outlet of the automatic pressure drain valve (2).

<b>⚠ WARNING</b>	
	<b>INJECTION HAZARD</b> The material hose (85b) must have a spring guard at the end which is installed at the outlet of the automatic pressure drain valve. The spring guard helps protect the hose from stress and strain which could cause the hose to rupture.

4. Connect the gun air hose (85a) to the Easy Spray Control (75).
5. Connect additional material and air hoses up to 150 foot (45 m). See page 38 to order.
6. Connect the air and material hoses to the gun and tighten securely.
7. Connect a 1/2 inch ID compressor air hose (customer supplied) to the air regulator inlet (C). Do not use quick disconnect couplers.
8. Tighten the pump's lug nut (214) very tight using a hammer. This helps prevent air leaks which prevent priming.
9. Clamp the siphon hose to the pump. Be sure the gasket is in place in the quick disconnect elbow (1e) – air leaks will prevent priming.
10. Connect the drain hose (86) to the rear outlet of the automatic pressure drain valve (2).
11. Install the hose clips (83) on the siphon hose and drain hose as shown.

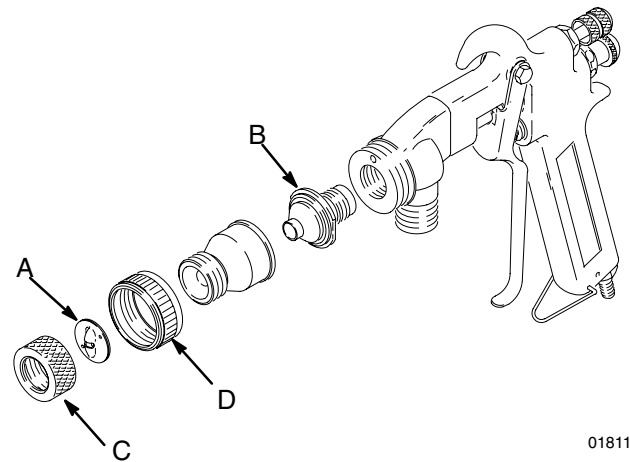

Fig. 6

01811

12. See page 9 for disc and nozzle recommendations. Install the disc (A) and nozzle (B) on the gun, as shown in Fig. 6. Tighten the retaining rings (C and D) snugly, but do not use a wrench.
13. Add Throat Seal Liquid, supplied, to the pump wet cup (B) until it is visible at the top of the cup.
14. Check the engine oil level. Refer to the Honda engine manual, supplied. In summary: remove one oil fill plug (E) – the oil should be almost overflowing. Add oil as necessary. Also read the **Maintenance** section on page 12.  
  
Recommended engine oil: Use a high-quality, detergent oil, SAE 10W-40, classified "FOR SERVICE SE or SF".  
  
**NOTE:** The engine stops automatically, or will not start, if it is low on oil. If you try to start it again without adding more oil, a red light near the engine on/off switch glows as you pull the starter rope.
15. Fill the gas tank. See **Fueling**, page 11.
16. Agitate or mix the material thoroughly! Make sure the heavier material on the bottom of the container is completely mixed in.
17. Start the sprayer. See page 8.

# Startup

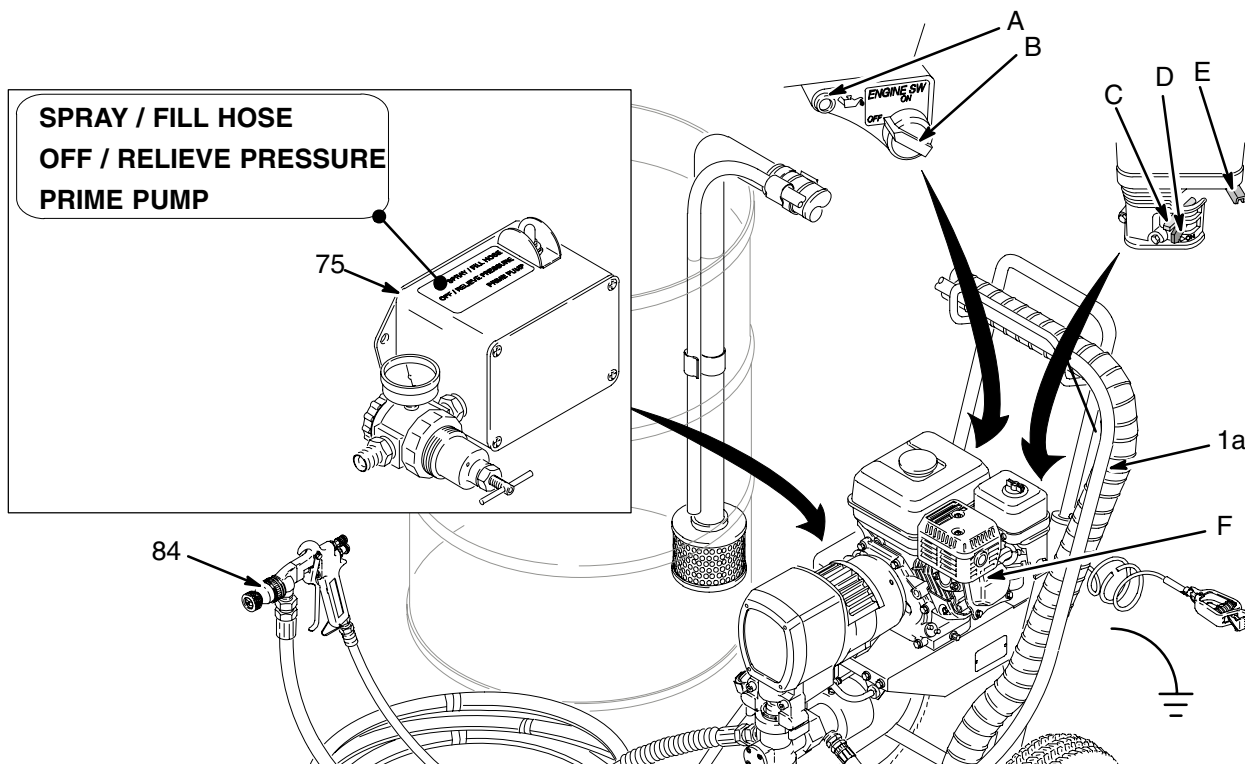

Fig. 7

01794

## ⚠ WARNING



INSTRUCTIONS

### EQUIPMENT MISUSE HAZARD

In the GM 1030 Texture Sprayer, the fluid pressure is relieved automatically when the gun trigger is released. However, to further reduce the risk of injury, including injury from moving parts, always follow the **Pressure Relief Procedure** when you are not spraying and before checking or adjusting the system.

If you are using the 1.2 gpm (GM 3012) high pressure paint pump, follow the Pressure Relief Procedure in manual 308127.

## Prime the Pump

**NOTE:** Before you start the sprayer for the first time, flush out the lightweight oil left in for storage. See **Flushing** on page 10.

1. Route the siphon hose (1a) and drain hose over the cart's hose rack and into the water or solvent container.
2. Set the Easy Spray Control (75) to **OFF**.

**NOTE:** Always start the sprayer in the **OFF** mode.

3. Turn the gun's Air Control Valve (G) fully in.
4. **Start the engine:**
  - a. Turn **ON** the engine switch (B).
  - b. Open the black fuel shutoff lever (C) by pushing it in the direction of the arrow.
  - c. Slide the throttle lever (E) fully left to the maximum position.
  - d. If the engine is cold, close the choke (D) (fully left).
  - e. If the engine is warm, close the choke half way or not at all.

## Pressure Relief Procedure

1. Turn the Easy Spray Control to **OFF**.
2. Turn the engine stop lever to **OFF**.

## ⚠ CAUTION

Always start the sprayer using water or a compatible solvent and circulate the solvent for at least one minute to wet the pump and hoses before priming with the texture material. This helps prevent material from packing out the hoses.



# Startup

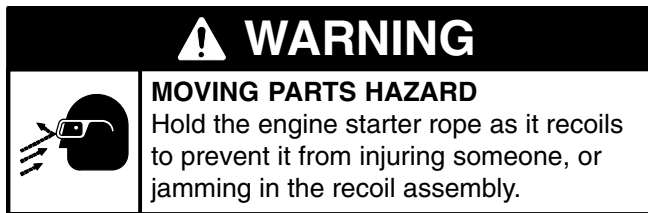

- f. Hold the frame of the sprayer with one hand and pull the starter rope rapidly and firmly. Continue holding the rope as it returns. Repeat until the engine starts.
- g. Open the choke as soon as the engine starts, except in cold weather. In cold weather, leave the choke closed for 10 to 30 seconds before opening it to keep the engine running.

## 5. Prime with texture material:

**NOTE:** If the pump does not prime easily, remove the suction strainer.

- a. Reduce the engine speed.
- b. Put the siphon hose (1a) in the prepared texture material.
- c. Set the Easy Spray Control to **PRIME** to load the pump. Set the control to **SPRAY** when material appears at the drain hose.
- d. Trigger the gun and direct the solvent into the solvent container, then when the texture material appears, direct the flow into a material drum. If you are ready to adjust the spray pattern, do not release the trigger.

## 6. Fill the pump:

- a. Start the air compressor and adjust the pressure according to the chart on page 9, or to at least 40 psi (0.28 MPa, 2.8 bar)
- b. Set the Easy Spray Control (75) to **SPRAY**.
- c. Trigger the gun for about one minute, directing the fluid back into the solvent container. (Air will exit the rear of the gun.) ***This starts the pump and wets the hoses.***
- d. Release the trigger. The system pressure will be relieved automatically.

## 7. To adjust the spray pattern:

- a. While triggering the gun, adjust the engine RPM to determine fluid flow and pressure. A good starting point is to adjust the fluid flow until you have an 8 in (20 cm) stream.

- b. Hold the gun 18 to 30 in (0.5 to 1.0 m) from a test surface. Test the spray pattern while backing out the gun's Air Control Valve (G) which allows the air to atomize the fluid. Adjust the Air Control Valve to obtain the desired spray pattern.

**TIP:** More fluid flow = more air,  
and less fluid flow = less air.

- c. If you cannot get a good spray pattern, try adjusting the air compressor pressure or try another spray disc and nozzle combination.

## 8. To prevent material surge at the beginning of a spray pattern:

- a. ***Always trigger the gun fully.***

If triggered partially, which only triggers the air portion of the system, the pump will start and pressurize the hoses. Then when you complete the triggering action you will get a blast of unatomized material.

- b. ***When you release the gun trigger, allow the material to completely depressurize before triggering the gun again.***

Failure to do this will result in spraying some unatomized material, cause material to back up into the gun air passages and block air flow. Longer hoses and heavier material may take a few seconds longer to depressurize.

As you test the spray pattern, also time how long it takes to depressurize the system and keep that in mind as you are working.

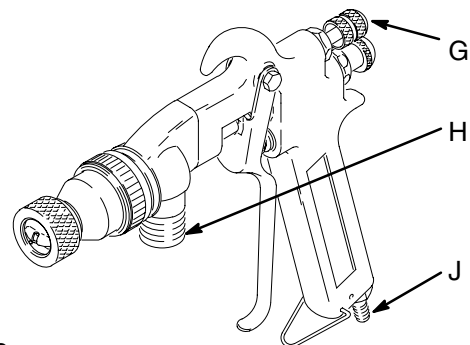

Fig. 8

01808

## CAUTION

Use the lowest fluid pressure and the lowest throttle setting needed. Higher settings cause excessive drain time from the dump valve and premature seal wear.

9. **When you stop spraying** release the gun trigger to relieve pressure. Shut off the sprayer.

# Flushing

**NOTE:** Several flushes are often required to thoroughly clean the system and prepare it for the next fluid to be sprayed, or to store the sprayer. Use this chart to determine the required flushes for the fluids you are using, and then follow the procedure below for flushing.

\*Use this category for flushing a brand new sprayer and flushing after storage.

System has this fluid in it:	Next fluid to be sprayed.	Flushing order:			Before you spray or store sprayer:
		Flush 1	Flush 2	Flush 3	
*Oil-base fluid	Oil-base fluid – new color	Mineral spirits	none	none	Prime with oil-base fluid
Oil-base	Water-base fluid	Mineral spirits	Warm soapy water	Clean water	Prime with water-base fluid
Oil-base solvent or fluid	Prepare for storage	Mineral spirits	none	none	Relieve pressure, Leave drain valve open
Water or water-base fluid	Water-base fluid – new color	Warm soapy water*	Clean water	none	Prime with water
Water or water-base fluid	Oil-base fluid	Warm soapy water*	Clean water	Mineral spirits	Prime with oil
Water or water-base fluid	Prepare for storage	Warm soapy water*	Clean water	Mineral spirits	Relieve pressure, Leave drain valve open

\*We recommend using Graco Gold Soap, 162805.

**NOTE:** Refer to Fig. 8 and 9.

1. Setup – prepare a pail of warm, soapy water or solvent. Turn the gun's Air Control Valve (G) all the way in. Start the sprayer in the **OFF** mode.
2. Set the Easy Spray control to **SPRAY**.
3. Trigger the gun. Direct the spray material into a waste container until the flushing fluid appears. Now direct the flushing fluid into the flushing pail, secure the trigger bail to keep the gun triggered and circulate the fluid until the gun and hose are thoroughly flushed.
4. Release the trigger – pressure will be relieved automatically.
5. Set the Easy Spray control to **PRIME**.
6. Circulate the flushing fluid through the pump, siphon hose and drain hose until well flushed.
7. If you are going to prime the system to spray, see page 8.

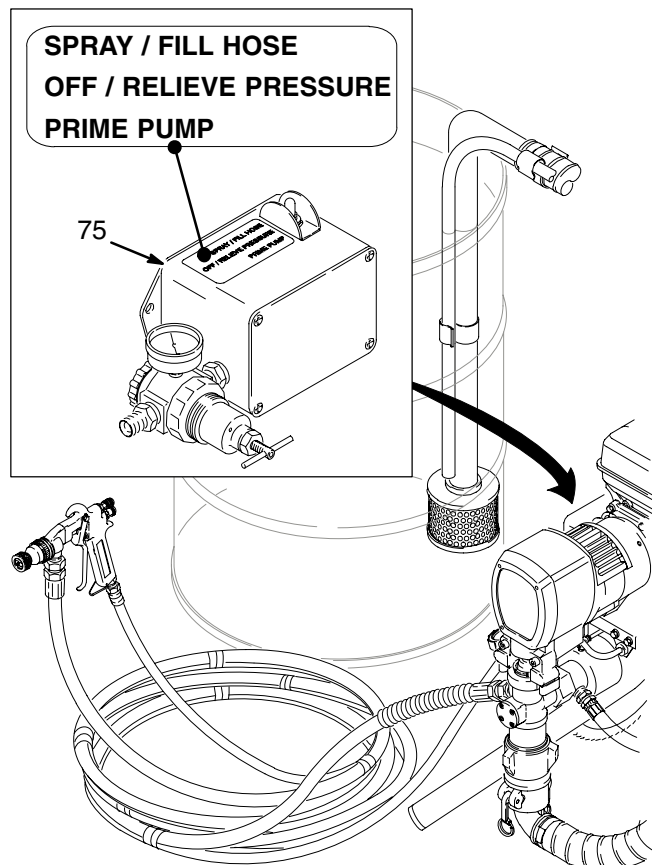

**Fig. 9**

# Helpful Hints

- **A spraying distance of 18 to 30 inch (0.5 to 1.0 m)** is recommended for most applications.
- **Keep the gun triggered and moving** as much as possible.
- **Set the gun's trigger bail** to hold the trigger open and reduce operator fatigue on large area surfaces.
- **When releasing the trigger** wait until the system pressure is fully relieved before triggering the gun again to eliminate a blast of unatomized material.
- **Simulated acoustic material with polystyrene** texture compresses easily so the system pressure builds up more slowly.
- **When spraying elastomerics**, maintain a wet edge, spray vertical passes followed by horizontal passes. Then hold the gun further away and “dust” in the area to blend in the pattern.
- **To spray ceilings** as high as 9 to 12 feet (3 to 4 m) without using stilts or scaffolding, adjust the engine for a higher revolutions per minute and open the gun's Air Adjustment Valve more to project the material onto the ceiling, and increase the regulator air pressure.
- **To spray a small, confined area**, you may be able to restrict the spray pattern sufficiently by restricting the gun's air. For further adjustment, reduce the engine revolutions per minute.
- **Check the material consistency periodically.** The material may thicken as it sits which slows down production. Check and thin the material as needed to maintain proper consistency.

## Fueling

<b>! WARNING</b>	
	<b>GASOLINE ENGINE HAZARD</b> Gasoline is extremely flammable and explosive under certain conditions. To reduce the risk of a fire or explosion follow the <b>Refueling Procedure</b> carefully.

### Fuel Specifications

1. Use automotive gasoline with a pump octane number of 86 or higher. If the engine knocks or pings, use a higher octane fuel.
2. Unleaded fuel minimizes combustion chamber deposits.
3. If using gasohol, it may contain no more than 5% methanol, and it must have methanol cosolvents and corrosion inhibitors.

**NOTE:** The HONDA engine warranty does not cover damage resulting from the use of gasolines containing alcohol.

4. Do not use oil and gasoline mixtures or contaminated gasoline.

### Refueling Procedure

1. Shut off the engine before refueling.
2. Refuel in a well-ventilated area. Do not smoke or allow flames or sparks in the area where the engine is refueled or where the gasoline is stored.
3. The tank capacity is 0.95 gallon (3.6 liter). Leave 1/2 inch (13 mm) at the top of the tank for gas expansion.
4. Fuel vapor or spilled fuel can ignite. If any fuel is spilled, make sure the area is dry before starting the engine.
5. Tighten the fuel tank cap firmly.

<b>! CAUTION</b>
Close the black fuel shutoff lever whenever you are transporting the sprayer to prevent fuel from flooding the engine.
Keep the sprayer upright and level when operating it and when transporting it. This prevents crank-case oil from leaking into the combustion chamber, which makes start up very difficult.

# Maintenance

## CAUTION

For detailed engine maintenance and specifications, refer to the separate HONDA engine manual.

## CAUTION

Close the black fuel shutoff lever whenever you are transporting the sprayer to prevent fuel from flooding the engine.

Keep the sprayer upright and level when operating it and when transporting it. This prevents crankcase oil from leaking into the combustion chamber, which makes startup very difficult.

**Daily:** Check the engine oil level and fill as needed.

**Daily:** Check and fill the gas tank.

**After the first 20 hours of operation and each 100 hours thereafter:** Change the oil.

**Weekly:** Remove the air filter cover and clean the element. In very dusty environments, check the filter daily. Replace the element as needed. Replacement elements can be purchased from your local HONDA dealer.

**Spark plug:** Use only a (NGK) BP6ES or BPR6ES plug. Gap the plug to 0.025 to 0.030 in. (0.7 to 0.8 mm). Always use a spark plug wrench.

# Troubleshooting

## WARNING

To reduce the risk of a serious injury due to the sprayer starting unexpectedly, always shut off the engine and disconnect the spark plug before performing any checks or service.

Check everything in the chart before disassembling the sprayer.

PROBLEM	CAUSE	SOLUTION
Engine won't start	Engine switch not on	Turn on engine switch.
	Out of gas	Refill gas tank.
	Engine oil level low	Try starting engine. If light on rear of engine glows, replenish oil.
	Spark plug cable disconnected or spark plug damaged	Connect cable on top of engine or replace spark plug.
Engine won't "fire" or "pull over"	Oil seepage into combustion chamber	Remove spark plug. Pull starter rope 3 or 4 times. Clean and replace plug. Try to start. Keep sprayer upright to avoid oil seepage.
Engine operates, but displacement pump doesn't  <i>Also see manual 308127.</i>	Easy Spray Control set wrong	Set in SPRAY mode.
	Air supply to Easy Spray Control or gun is not connected	Check and tighten connections.
	Air compressor not on	Start compressor.
	Engine RPM too low	Increase.
	Air leak at pump foot valve or siphon tube elbow	Be sure foot valve is tightened each day. Be sure seal in elbow is in place and is not worn or damaged.
	Tip clogged	Clean tip.
	Insufficient compressor air	Increase SCFM or compressor size. System requires a minimum of 30 psi (0.28 MPa, 2.8 bar) to run.
	Displacement pump rod seized by dry coating	Service pump. See page 19.
	Connecting rod worn or damaged	Replace connecting rod. See page 22.
	Drive housing worn or damaged	Replace drive housing. See page 23.
Clutch worn or damaged	Service clutch. See page 26.	
Pinion assembly worn or damaged	Service pinion assembly. See page 24.	
Engine starts but dies	Oil level drops below oil sensor	Add oil.
Sudden pressure loss	System has overpressurized, which opened the Pressure Drain Valve	Check for plugged tip or hose and correct. Restart pump.
	Air to sprayer or gun stopped	Check, correct.

PROBLEM	CAUSE	SOLUTION
Loss of air control or volume at gun	Air passages clogged with material	After releasing the gun trigger, make sure the system is fully depressurized before triggering the gun again. This helps prevent material backing into gun passages.
Displacement pump output low on upstroke	Piston ball (220) not seating	Clean piston area. See page 20.
	Piston packings worn or damaged	Replace packings. See page 20.
	Siphon hose coupling gasket (1e) worn or missing.	Replace or install gasket.
	Pump cylinder o-ring (205) worn or missing	Check and replace.
Displacement pump output low on downstroke or both strokes	Siphon hose strainer is clogged	Clean strainer.
	Piston packings worn or damaged	Replace packings. See page 20.
	Intake valve ball (216) not seating properly	Clean and service intake valve. See page 19.
	Clutch (9) worn or damaged	Replace clutch. See page 26.
Material leaks into wet-cup	Loose wet-cup (202)	Tighten wet-cup just enough to stop leakage.
	Throat packings worn or damaged	Replace packings. See page 20.
	Displacement rod (201) worn or damaged	Replace displacement rod. See page 20.
Low fluid delivery	Siphon hose strainer is clogged.	Clean or remove strainer.
	Engine RPM too low	Increase throttle setting. See <b>Startup</b> , Steps 4, page 13.
No fluid delivery	Easy Spray Control not set to SPRAY mode	Reset.
	Compressor is not on and/or air hoses are not properly connected	Check and correct.
	Gun is not fully triggered	Squeeze trigger firmly and completely.
Spitting from gun	Fluid supply is low or empty	Refill and prime the pump. See <b>Startup</b> , page 13. Check fluid supply often to prevent running the pump dry.
Heavy or poorly atomized material when gun is first triggered	Fluid pressure was not allowed to fully self relieve after releasing gun trigger	Wait a little longer between releasing gun trigger and pulling it again.
	Gun was not fully triggered immediately when squeezed, causing gun air passages to clog with material.	Always squeeze the trigger fully to prevent just the air from turning on, which starts the pump and pressurizes the hoses. Disassemble and clean gun.
Fluid from gun is not atomized, or has insufficient atomization	Gun's Air Control Valve is turned fully in	Turn valve out for desired atomization.
	Insufficient compressor air	Increase SCFM or compressor size.
	Gun nozzle too small for application	Increase nozzle size.
Fluid from the gun is pulsing	The fluid is too thin.	Install the optional flow restrictor, 190109

# Removing and Installing a Pump

## Removal

### ! WARNING

To reduce the risk of injury due to sprayer starting unexpectedly, shut off engine and disconnect spark plug before performing checks or service.

1. Flush the sprayer. Remove the suction hose. Remove the outlet hose.

### ! WARNING



#### MOVING PARTS HAZARD

To reduce the risk of amputating fingers, keep fingers away from the connecting link and pin while jogging the engine.

2. Start the engine. Jog the Easy Spray Control between PRIME and OFF until the connecting link stops near the bottom of the stroke and is fully exposed. See Fig. 10. Shut off the engine.
3. Unscrew the collar (C) and disconnect the power supply cord from the control (75). See Fig. 11.
4. Loosen the two mounting screws (60). See Fig. 10.
5. Use a screwdriver to push in the connecting link pin (228) just until you can gently pry the retaining ring up (61) from the back of the connecting link (22). Then push the pin in so it falls out the back.
6. Remove the two mounting screws (60) while supporting the weight of the pump with your free hand. See Fig. 10.
7. Disconnect the cables (D) from the pressure drain valve. See Fig. 12.
8. Unscrew the gauge, using a 1.062 inch wrench. Unscrew the pressure drain valve assembly from the pump.

## Installation

1. Screw the pressure drain valve into the pump. Install the gauge.
2. Push the pin (228) slightly into the connecting link (22), but not into the mating hole of the pump.
3. Pull the piston rod (201) out of the pump 2 to 3 inches (50 to 75 mm).
4. Align the flats of the pump piston rod and the pump outlet. Lift the pump into position and gently push on the pin (228) while moving the pump slightly until the pin slips into the hole. Be sure the retaining ring (61) snaps down over the end of the pin. Check the back of the bearing housing to be sure the parts are installed properly. See Fig. 10.

### ! WARNING

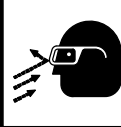

#### MOVING PARTS HAZARD

To reduce the risk of a serious injury or property damage if the pin (228) comes loose, be sure the retaining spring is completely in the groove of the connecting link to prevent it from working loose due to vibration.

5. Lift the pump to align the mounting holes and install the mounting screws. IMPORTANT – torque the screws to 20 ft-lb (27 N.m). See Fig. 10.
6. Connect all cables (D) to the pressure drain valve. See Fig. 12. Plug in the power cord so the notch (B) in the collar (C) and the tab (A) in the socket align. Screw on the collar. See Fig. 11.

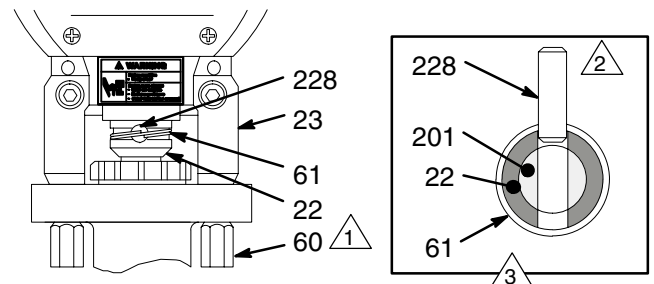

- 1 Torque to 20 ft-lb (27 N.m)
- 2 Back of pump
- 3 Cutaway view shows how pin (228) goes through connecting rod

Fig. 10

0407

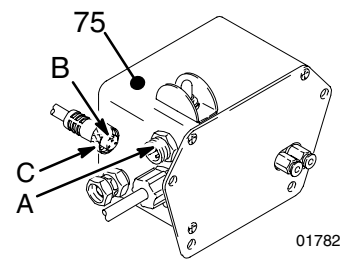

Fig. 11

01782

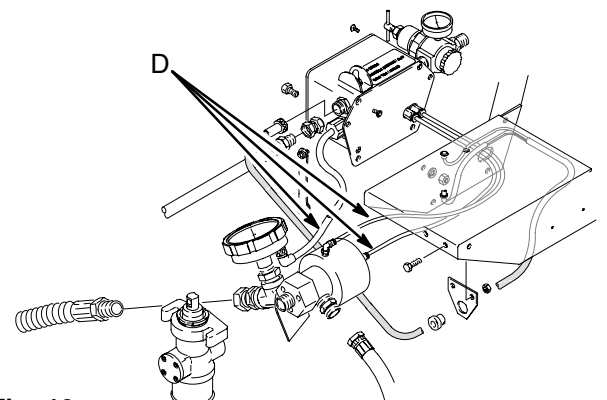

Fig. 12

# Pump Repair

## WARNING

To reduce the risk of a serious injury due to the sprayer starting unexpectedly, always shut off the engine and disconnect the spark plug before performing any checks or service.

### Disassemble the Pump

1. See page 15 for how to remove the pump.
2. Use a hammer on the tabs of the lug nut (214) to loosen the foot valve housing.
3. Disassemble the pump, but do not disassemble the piston rod (201) from the piston housing (206) unless one of those parts needs to be replaced. Due to the high-strength (red) Loctite® used at the joint of these two parts, the joint must be heated before disassembly. Refer to Fig. 14.

### Clean and Inspect All Parts

1. Use a compatible solvent to thoroughly clean all parts and remove all traces of sealant.
2. Inspect the parts, including the seats, for nicks and scratches. Replace worn or damaged parts as they cause the packings to wear more quickly and may result in poor pump performance.

### Repair Kit

A Packing Repair Kit, Part No. 235186, is available. Use all the parts in the kit for the best results. Change the pressure drain valve u-cup packing (included in kit) when you repack the pump.

Parts included in the kit are marked with an asterisk in the text and drawings. For example, 208\*.

### Reassemble the Pump

**NOTE:** Refer to Fig. 14.

1. If you disassembled the piston rod (201) and piston housing (206), clean the threads thoroughly. Apply Loctite primer and then red Loctite to the threads and torque to 80 to 100 ft-lb (110 to 135 N.m). Allow to dry at least one hour.
2. Assemble onto the piston seat (213): washer (212); u-cup seal (218\*) with lips toward ring; female gland (211\*) and then alternate the white (210\*) and purple packings (219\*), all with lips facing up; male gland (209\*).

3. Install the nut (208\*) on the piston seat (213). Hand tighten the nut very firmly.
4. Install the ball (220\*) in the piston housing (206).
5. Apply blue Loctite (supplied in kit) to the piston seat (213) threads and screw the assembly onto the rod, hand tight.

**TIP:** Use a felt tip marker to draw a line across the male gland, nut and piston housing to use as a visual reference when tightening the piston and nut.

6. Place the piston seat (213) in a vise. Hold the packing nut (208) steady with one wrench and use a torque wrench to tighten the rod assembly to 90–125 ft-lb (122–170 N.m). Make sure the line you made in step 5 is still aligned.
7. Grease the throat of the intake housing (227). Assemble into the throat: male gland (204\*), flat side first; alternate white packings (225\*) and purple packings (203\*) and then the female gland, all with lips facing down. Install the packing nut (202) and tighten firmly by hand.
8. Grease the piston packings and inside the throat packings.
9. Grease the new o-rings (205\*) and install on the cylinder (221). Slide the cylinder into the bottom of the intake housing (227) until you hear it snap.
10. Guide the piston rod assembly into the cylinder so the piston rod flats are aligned with the opening in the front of the pump. Push down until you hear another snap. Turn the pump over and push the assembly the rest of the way in.
11. If the rod hole is not aligned with the front of the pump, use a screw driver through the rod hole to turn it into place.
12. Grease the o-ring (223\*), install on the plug (224), install the plug and the screws (222) loosely. Torque the screws to 50–70 in-lb (5.6–8 N.m) in a crosswise pattern.
13. Install the ball (216\*) and ball guide (217) into the foot valve. Place the pump assembly on the foot valve and push into place.
14. Screw on the lug nut (214). Use a hammer to tighten the lug nut securely.

**TIP:** The lug nut must be very tight or the pump will not prime. Use a felt tip marker to draw a line between the intake housing and the lug nut to use as a visual alignment reference during operation.



# Pump Repair

**NOTE:** Replace the u-cup packing (Graco P/N111829) whenever you repack the pump. The packing is supplied with the pump repair kit.

15. Remove the gauge (H), using a 1–1/16 inch wrench. Then remove the drain valve assembly using a 2–1/4 inch wrench.
16. Remove the three screws (E). Pull off the cap (F). Remove the packing (G). Install the new packing so the lips face into the cap. See Fig. 13.
17. Reassemble the drain valve. Torque the screws (E) to 40–50 in-lb (45–55 N.m) and screw it onto the pump.

18. Install the pump and prime it. Check the packing nut (202) and tighten it just enough to prevent leakage.

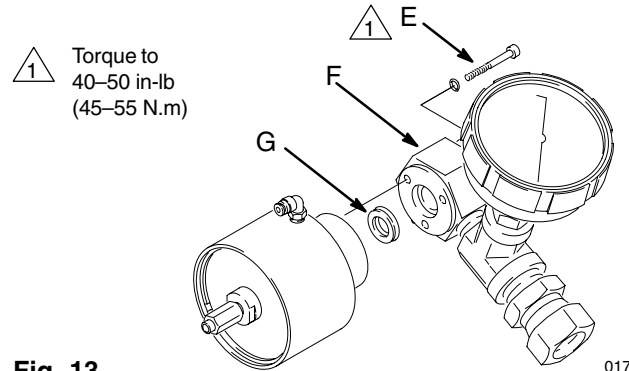

Fig. 13

01792

- 1 Grease inside of throat before installing packings
- 2 Lips of v-packings in throat must face down
- 3 Grease inside of packings after installing
- 4 Torque 50–70 in-lb (5.6–8 N.m) in crosswise pattern
- 5 Torque piston housing to piston seat (213) to 90–125 ft-lb (122–170 N.m) without changing alignment of packing nut
- 6 Lips of v-packings on piston must face up
- 7 Grease outside of packings after installing
- 8 Lips of U-cup seal on piston must face down
- 9 If piston seat and rod were separated, apply Loctite primer, then red Loctite, and torque to 80–100 ft-lb (110–135 N.m)
- 10 Tighten with hammer

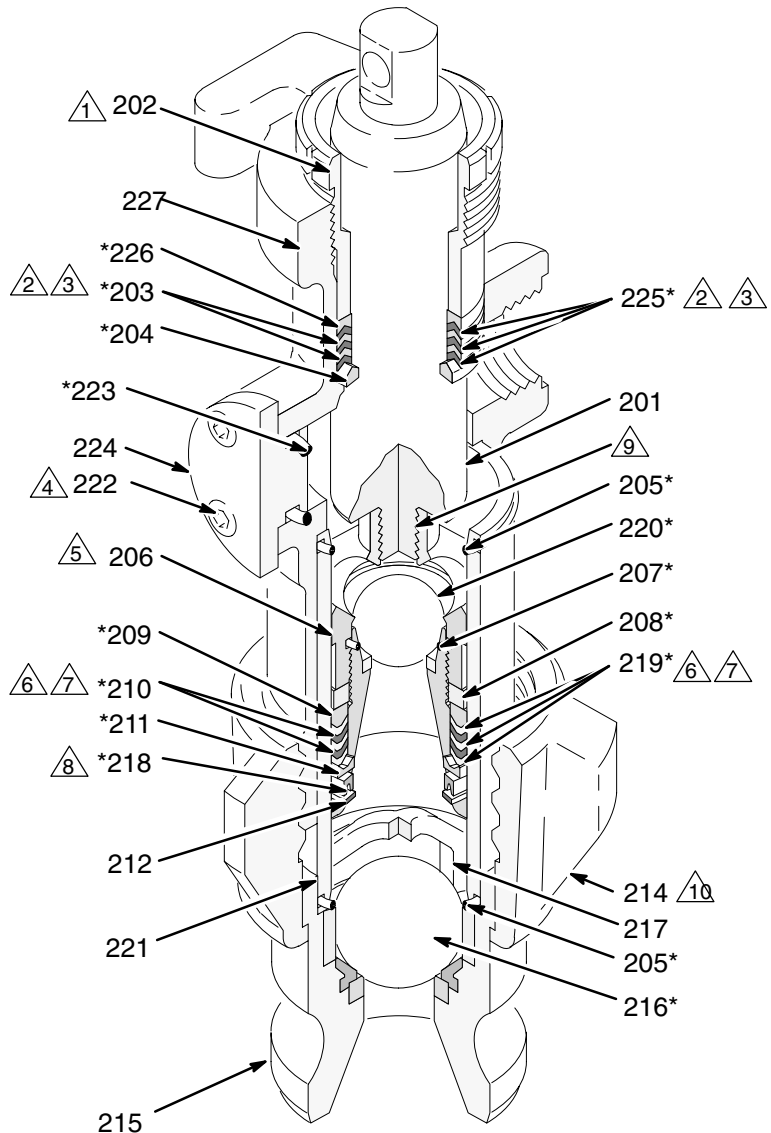

Fig. 14

01785

# Bearing Housing & Connecting Rod

## **⚠ WARNING**

To reduce the risk of a serious injury, always shut off the engine and disconnect the spark plug before performing any checks or service.

1. Refer to **Removing the Pump** on page 15.
2. Remove the screws (48) and lockwashers (49) from the bearing housing (23).
3. While pulling the connecting rod assembly (22) with one hand, lightly tap the lower rear of the bearing housing (23) with a plastic mallet to loosen it from the drive housing (20). Pull the bearing housing and the connecting rod assembly off the drive housing.
4. Inspect the crank (A) for excessive wear and replace the drive housing. See page 19.
5. Evenly lubricate the inside of the bronze bearing (E) in the bearing housing (23), and the inside of the connecting rod link (C), with high-quality motor oil (do not use grease). Liberally pack the roller bearing (B) in the connecting rod assembly (22) with bearing grease (20d), supplied.
6. Assemble the connecting rod (22) and bearing housing (23).
7. Clean the mating surfaces of the bearing (23) and drive (20) housings.
8. Align the connecting rod with the crank (A) and carefully align the locating pins (D) in the drive housing (20) with the holes in the bearing housing (23). Push the bearing housing onto the drive housing or tap it into place with a plastic mallet.

## **⚠ CAUTION**

DO NOT use the bearing housing screws (48) to align or seat it with the drive housing. These parts must be aligned using the locating pins (D), to help avoid premature bearing wear.

9. Install the screws (48) and lockwashers (49) on the bearing housing. Tighten the screws evenly to 25 ft-lb (34 N.m).
10. Refer to **Installing the Pump** on page 15.

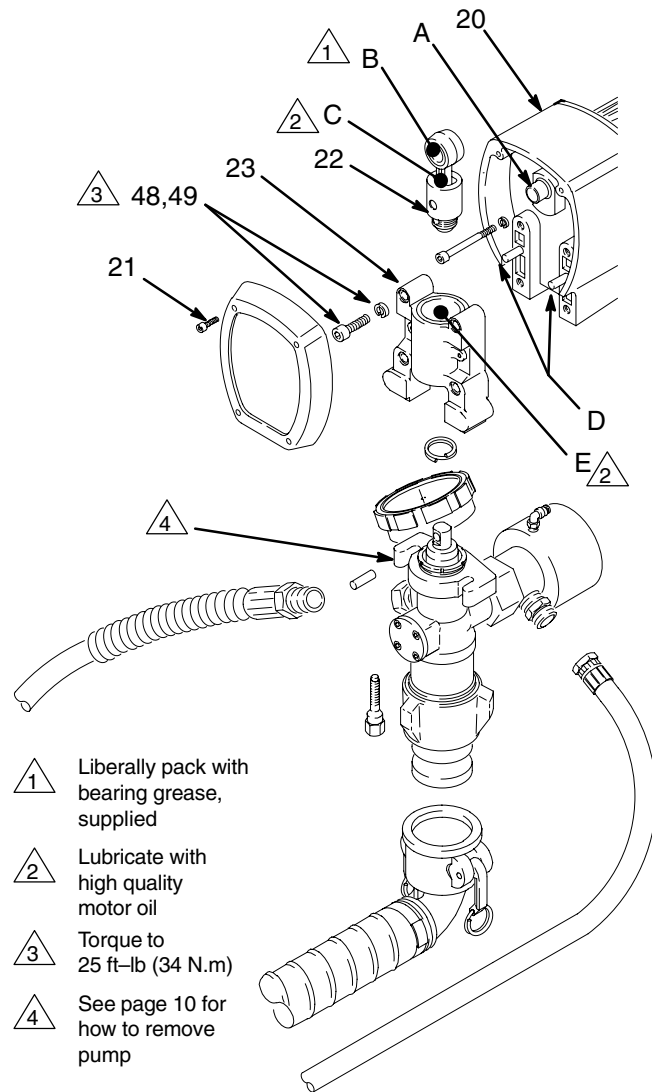

**Fig. 15**

01786

# Drive Housing

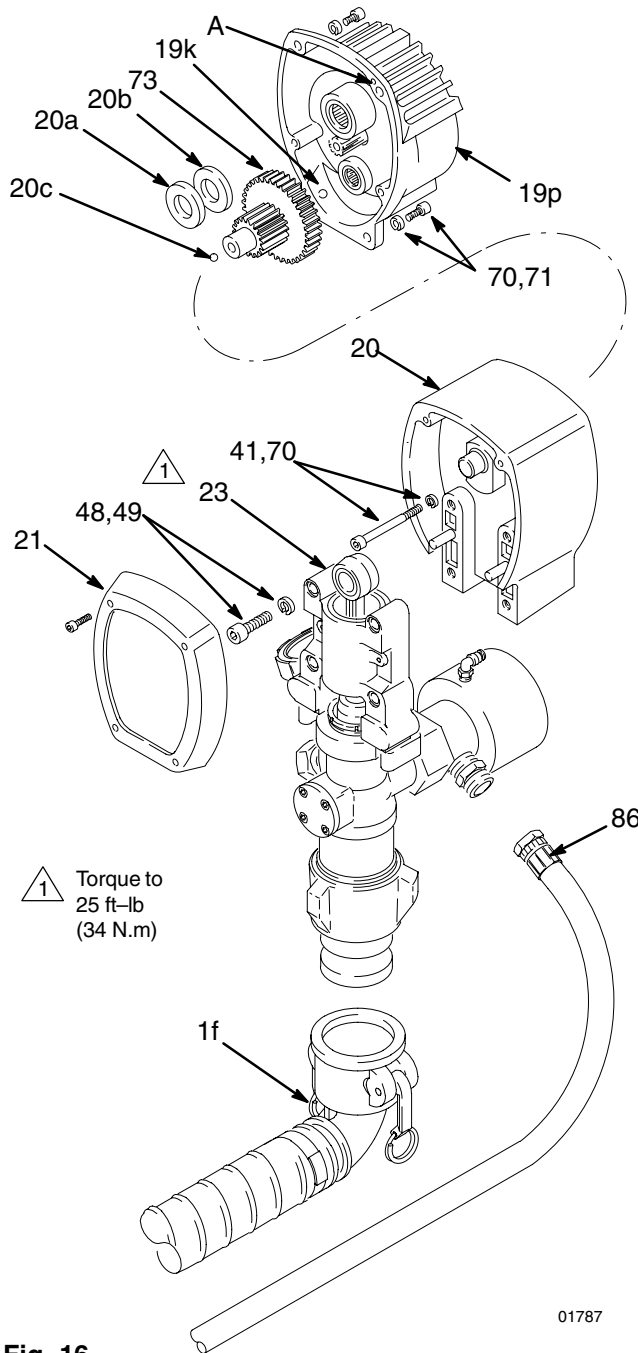

Fig. 16

## ⚠ WARNING

To reduce the risk of a serious injury due to the sprayer starting unexpectedly, always shut off the engine and disconnect the spark plug before performing any checks or service.

1. Disconnect the siphon hose elbow (1f), drain hose (86) and material hose (not shown). Disconnect the pump outlet hose. Disconnect the pressure control cord (62). Remove the front cover (21).
2. Remove the four screws (48) and lockwashers (49) from the bearing housing (23).
3. Lightly tap the back of the bearing housing (23) with a plastic mallet. Pull the pump, bearing housing and connecting rod away from the drive housing (20) as one assembly.
4. Remove the bearing housing screws (41) and the pinion housing screws (3).

## ⚠ CAUTION

DO NOT drop the gear cluster (1) when removing the drive housing (20). The gear cluster is easily damaged. The gear may stay engaged in either the drive housing or the pinion housing.

DO NOT lose the thrust balls (20c and 19k) located at each end of the gear cluster. The balls, which are heavily covered with grease, usually stay in the shaft recesses, but they could be dislodged. If they are caught between the gears and not removed, the balls will seriously damage the drive housing. If the balls are not in place, the bearings will wear prematurely.

5. Lightly tap around the drive housing (20) with a plastic mallet to loosen it from the pinion housing (19p).
6. Liberally apply bearing grease (20d, supplied) to the gear cluster (73). Be sure the thrust balls (20c and 19k) are in place.
7. Place the bronze colored washer (20a) and then the silver-colored washer (20b) on the shaft protruding from the big bearing of the drive housing (20). Align the gears and push the new drive housing straight onto the pinion housing and locating pins (A).
8. Reassemble the sprayer. Or, go to the next section in this manual if further service is needed.

# Pinion, Clutch, Clamp, Field & Engine

Disassembling these parts can start from the pinion housing or from the clutch, if no pinion service is needed.

*If starting from the pinion housing*, first follow Steps 1 to 5 of **Drive Housing**, on page 19, and then continue with the procedure below.

*If starting from the clutch*, see page 22.

## Pinion Housing

### Removing the Pinion Housing

#### **⚠ WARNING**

To reduce the risk of a serious injury due to the sprayer starting unexpectedly, always shut off the engine and disconnect the spark plug before performing any checks or service.

1. Remove the two bottom screws (3) first, and then remove the top three screws (3).
2. Pull the pinion housing (19p) away from the clutch housing (17). The armature (9b) will come with it.
3. Pull the armature (9b) off the hub (19j – see Fig. 19) of the pinion housing.

#### **⚠ CAUTION**

Do not lose the thrust ball (19k). Refer to the **CAUTION** on page 19 for more information.

**NOTE:** To disassemble the pinion, go to **Repairing the Pinion**, page 21. To disassemble more of the sprayer, go to page 23. To reassemble the sprayer from this point, go to **Reassembly**, page 27, Step 7.

### Repairing the Pinion

**NOTE:** Refer to Fig. 18.

**NOTE:** A hydraulic press is required if you purchase the pinion parts individually. Otherwise, use Repair Kit No. 221032, which includes the shaft and bearings pre-assembled and lubricated.

*If using Repair Kit 221032, follow Steps 1 to 5, below.*

1. Remove the small ring (19e\*\*) from the hub (19f) and the large ring (19m) from the bearing recess of the pinion housing (19p).
2. Push on the front of the shaft (19b\*\*) to force the bearing and hub assembly out of the housing (19p).

3. Install the new shaft assembly into the pinion housing, pushing it to the shoulder of the housing (19p).
4. Install the rings (19m and 19e\*\*).
5. Go to **Reassembly**, page 27, Step 7, or continue on page 22.

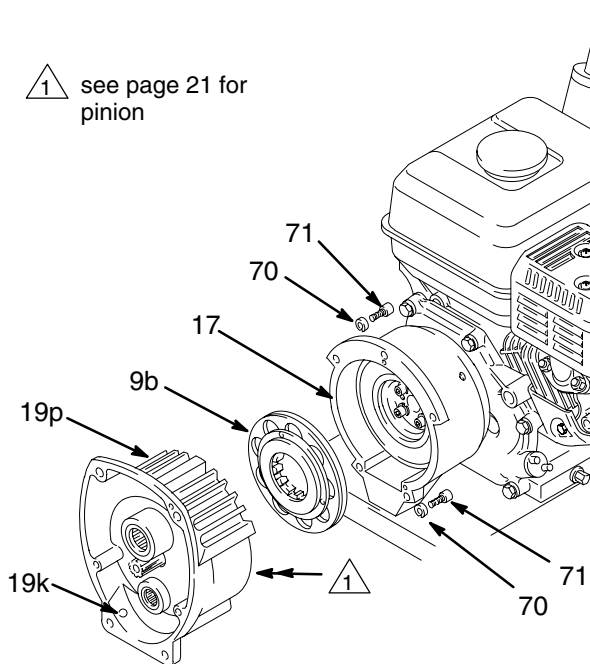

Fig. 17

0171

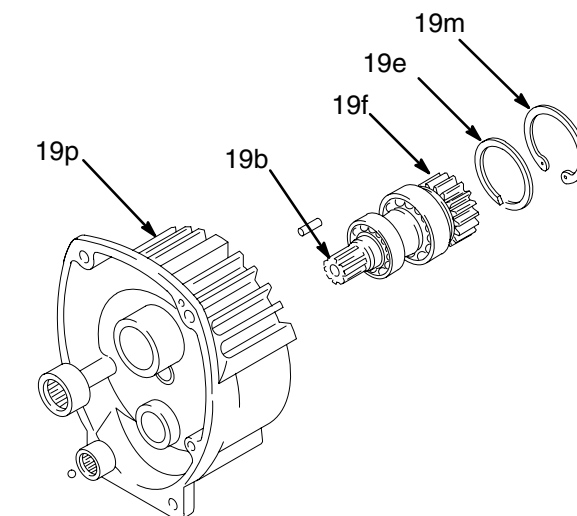

Fig. 18

0169

# Pinion Housing

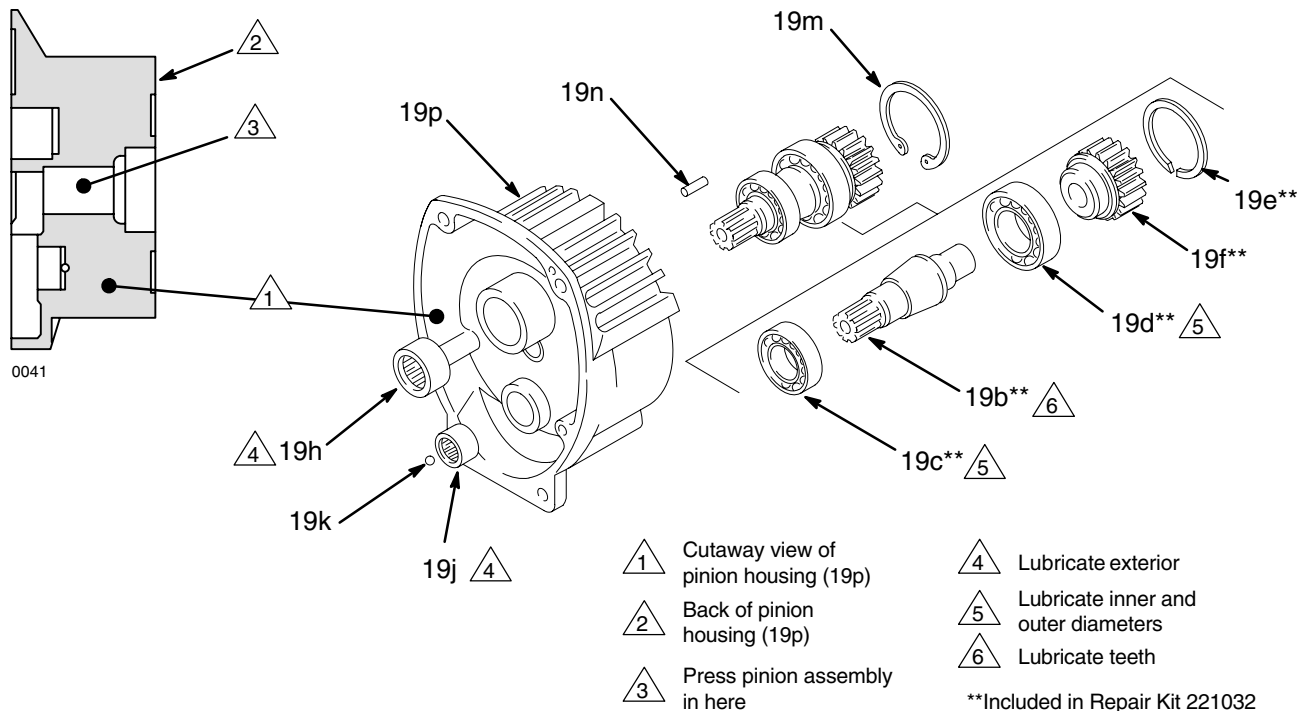

Fig. 19

0169

If purchasing parts separately, use these instructions. Disassemble as needed for the parts being replaced.

**NOTE:** Refer to Fig. 19, except where noted.

**NOTE:** The old bearings (19c and 19d) will be damaged when removed. Have extra ones on hand if you need to remove them for any reason.

1. Remove the small ring (19e) from the hub (19f).
2. Remove the snap ring (19m) from the bearing recess of the pinion housing (19p).
3. Push on the front of the shaft (19b) to force the bearing (19d) and hub (19f) assembly out of the housing.
4. **Using a hydraulic press**, place pieces of steel bar stock on the inner race of the large bearing (19d) and press the shaft through the hub and bearing. Then turn over the shaft and press out the small bearing (19c). See Fig. 20.
5. Apply lubricant to the parts as shown in Fig. 19.

6. Press fit the following parts: large bearing (19d) to the large shoulder of the shaft (19b); small bearing (19c) to the shoulder of the shaft (19b); hub (19f) onto the shaft (19b) all the way to the large bearing (19d).
7. Install the shaft assembly, pushing it to the shoulder of the housing (19p).
8. Install the snap ring (19m). Install the small ring (19e).
9. Go to **Reassembly**, page 27, Step 7, or continue on page 22.

**KEY**

- A Round steel bar to push on shaft (19b)
- B Hydraulic press
- C Steel bar stock
- D Two steel blocks (only one shown)
- E Press Platform

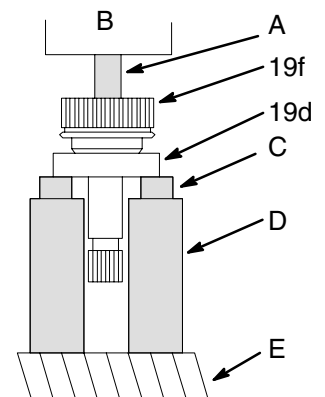

Fig. 20

0043

# Clutch

**NOTE:** The clutch assembly (9) includes the armature (9b) and rotor (9a). The armature and rotor must be replaced together so they wear evenly.

**NOTE:** If the pinion assembly (19) is not yet separated from the clutch housing, follow Steps 1 to 4. Otherwise, start at Step 5.

1. Follow the **Pressure Relief Procedure Warning** on page 17.
2. Disconnect the hose from the displacement pump. Disconnect the cord set (62) from the pressure control.
3. Remove the bottom two screws (3) from the clutch housing (17) and then remove the remaining three screws (3).
4. Tap lightly on the back of the bearing housing (23) with a plastic mallet to loosen the assembly (D) from the clutch housing (17). Pull the assembly away; the armature (9b) will come with it.

5. Remove the armature from the pinion.
6. There are two ways to remove the rotor (9a):
  - a. Remove the capscrews (4) and lockwashers (2). Install two of the screws in the threaded holes in the rotor (9a). Alternately tighten the screws until the rotor comes off. See Fig. 21.
  - b. Use a standard steering wheel puller (A) with two 1/4-28 x 3 or 4 in. long screws (B). Replace the short screws of the steering wheel puller with the longer screws. Turn the screws (B) into the threaded holes of the rotor (9a). Tighten the capscrew (C) of the tool until the rotor comes off. See the Detail in Fig. 21.
7. Skip ahead to **Reassembly**, page 27, Step 6, or continue on page 23.

- 1 Torque to 7 ft-lb (9.5 N.m)
- 2 Pinion shaft inside this housing
- 3 Threaded holes

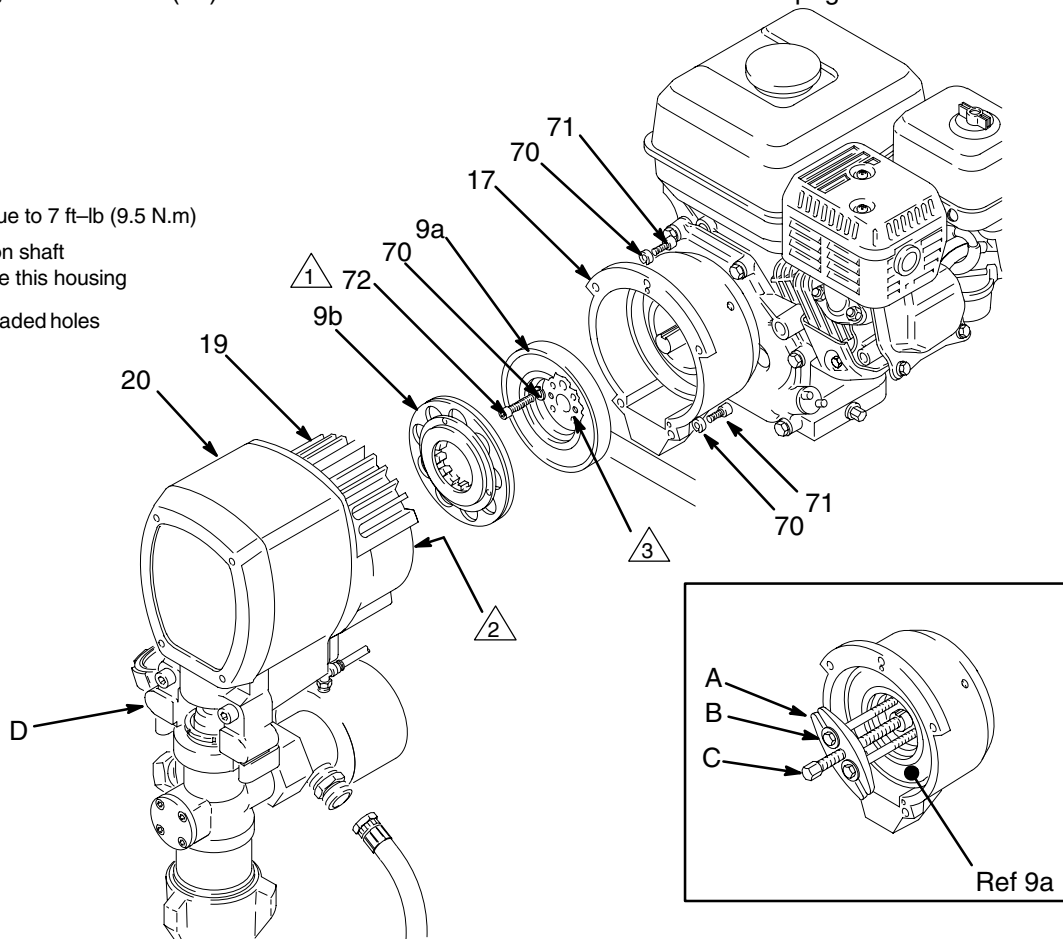

Fig. 21

01788

# Engine

1. Working under the mounting plate (E) of the cart, remove the screw (5), lockwasher (6) and washer (7). See Fig. 22.
2. Remove the engine-mounting locknuts (43) and screws (42). Disconnect the mating black, white and green wires. Pull the wires carefully through the grommets (8) before removing the engine. See Fig. 22 and 23.
3. Lift the engine carefully and place it on a work bench.
4. Remove the **Field and Wiring Harness, Clamp** and **Clutch Housing**, as instructed on pages 24 and 25.
5. Go to **Reassembly**, page 26, Step 1.

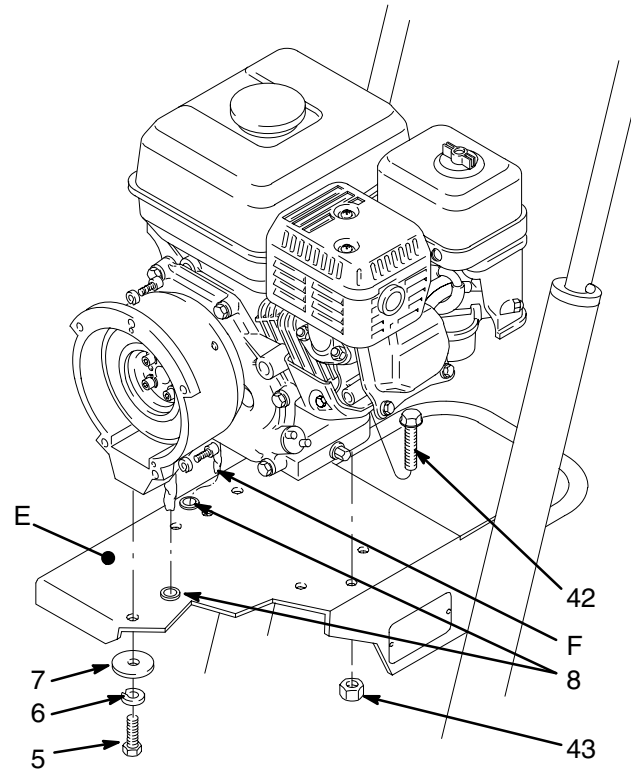

Fig. 22

0153

**NOTE:** All service to the engine must be performed by unauthorized HONDA dealer.

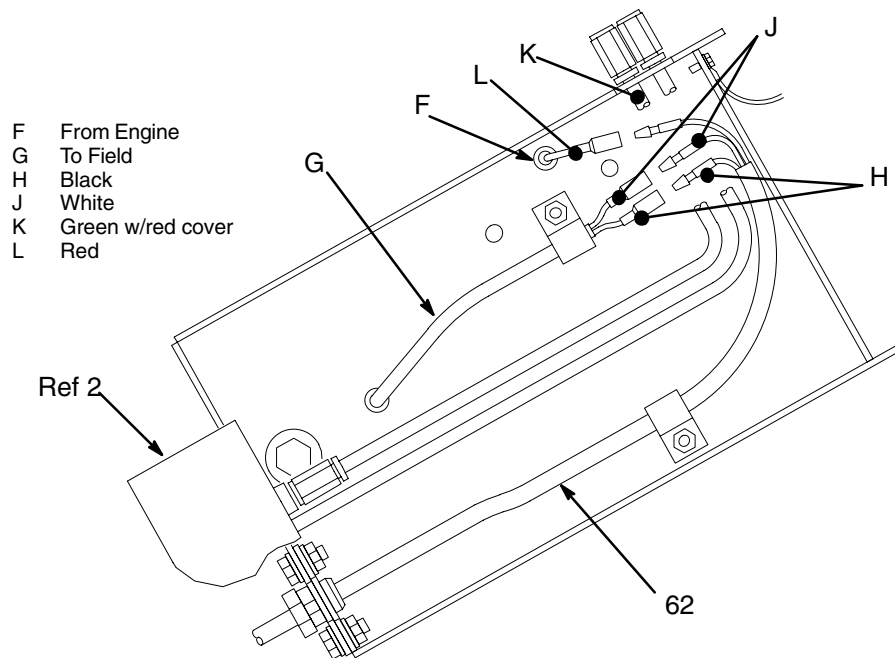

Fig. 23

VIEW FROM UNDER ENGINE MOUNTING PLATE

01789

# Field and Wiring Harness

**NOTE:** Refer to Fig. 24.

1. Remove the engine. See page 23.
2. Loosen the setscrews (16). Unplug the wiring harness (69) from under the engine mounting plate. Pull the field out to expose the black and white wires.
3. Pull the caps (A) off the wire screws (57) in both places on the field. Loosen the screws and release the wires of the harness (69).
4. Go to **Reassembly**, page 26, Step 4.

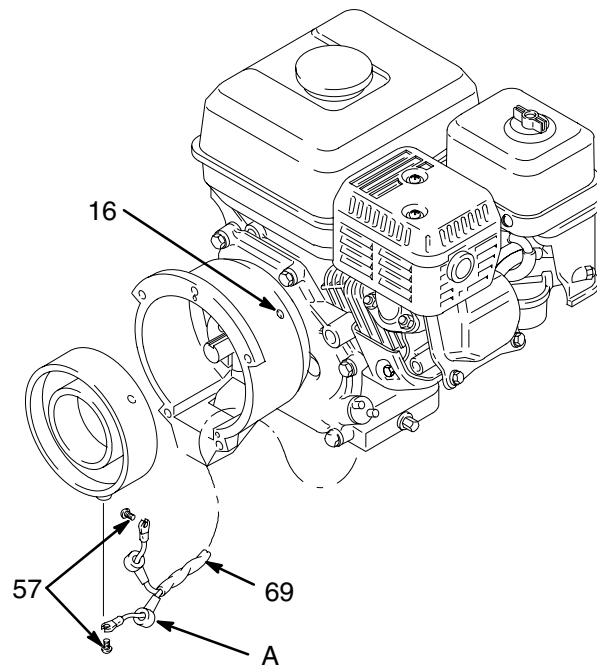

**Fig. 24**

0046



# Clamp

**NOTE:** A standard steering wheel puller and two 1/4-28 x 3 or 4 in. long screws are required to remove the clamp.

**NOTE:** Refer to Fig. 25.

1. Loosen the two screws (4) on the clamp (15), working through the slot at the bottom of the clutch housing (17).
2. Install two screws (B) of the tool (A) in two of the threaded holes in the clamp. Tighten the screw (C) until the clamp comes off.
3. Go to **Reassembly**, page 26, Step 3, or continue below.

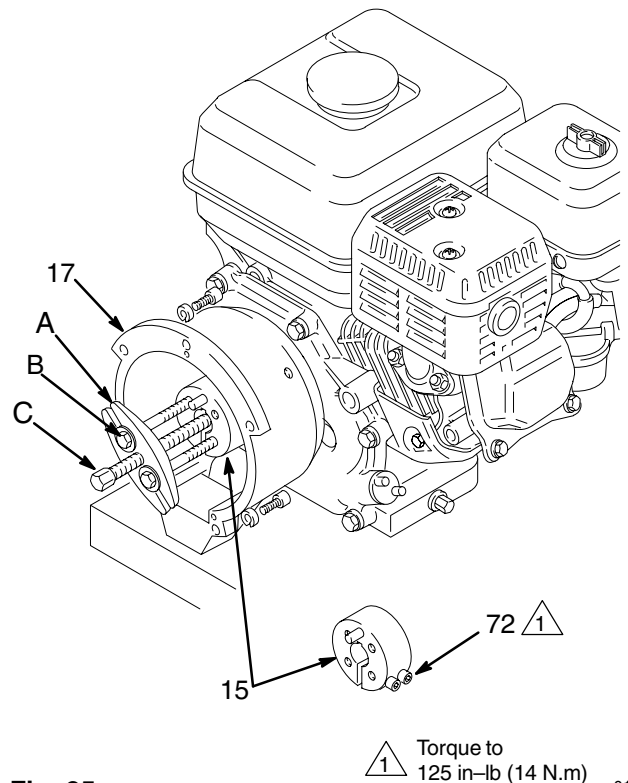

Fig. 25

1 Torque to  
125 in-lb (14 N.m)

0155

# Clutch Housing

**NOTE:** Refer to Fig. 26.

1. Remove the capscrews (11) and lockwashers (12) which hold the clutch housing (17) to the engine (45).
2. Remove the engine key (14).
3. Pull off the clutch housing (17).
4. Go to **Reassembly**, page 26, Step 1.

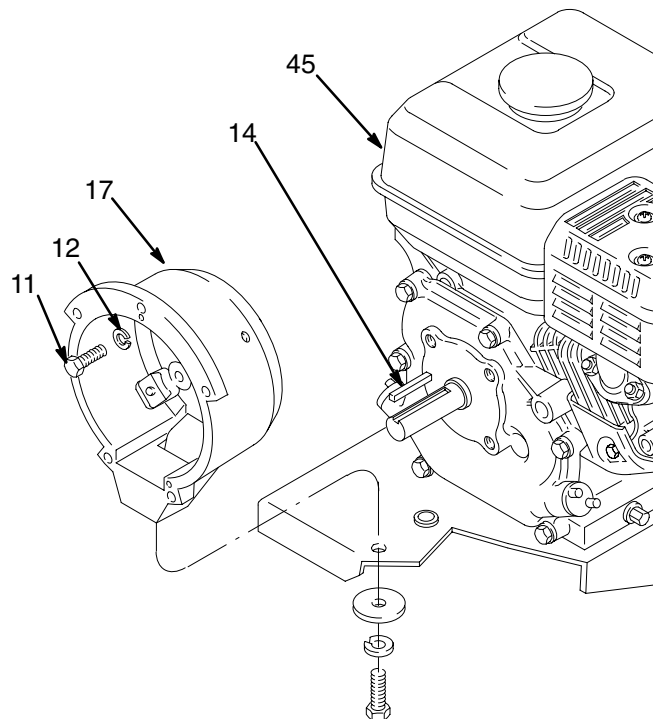

Fig. 26

# Reassembly

1. Install the **clutch housing (17)**, capscrews (11) and lockwashers (12) on the engine. See Fig. 27.
2. Install the engine shaft **key (14)**. See Fig. 27.
3. Install the **clamp (15)** onto the engine shaft (A). Maintain the 1.99 in.  $\pm$  0.01 (50.54 mm) dimension shown in Fig. 28.

To check the dimension, place a rigid, straight steel bar (B) across the face of the clutch housing (17). Use an accurate measuring device to measure the distance between the inside of the bar and the face of the clamp. Adjust the clamp as necessary. Torque the two screws (72) to 125 in-lb (14 N.m).

4. Connect the wires of the harness (69) to the screws (57) in both places on the field. Pull the plastic caps (C) up and snap them over the screws. Guide the wires of the harness (69) through the slot in the clutch housing. Slide the **field (10)** into the clutch. Align the setscrew chamfers in the field and the clutch housing (17). Tighten the setscrews (16) oppositely and evenly, to 25 in-lb (2.8 N.m). See Fig. 27.

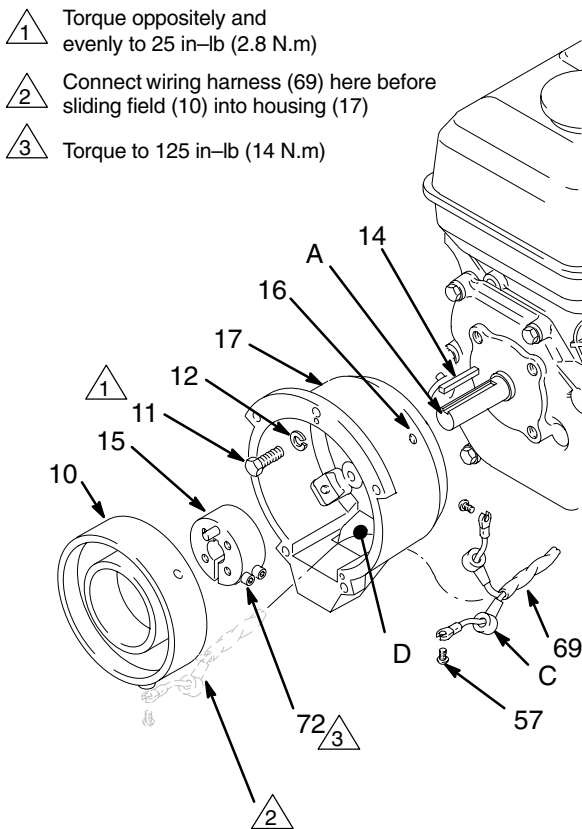
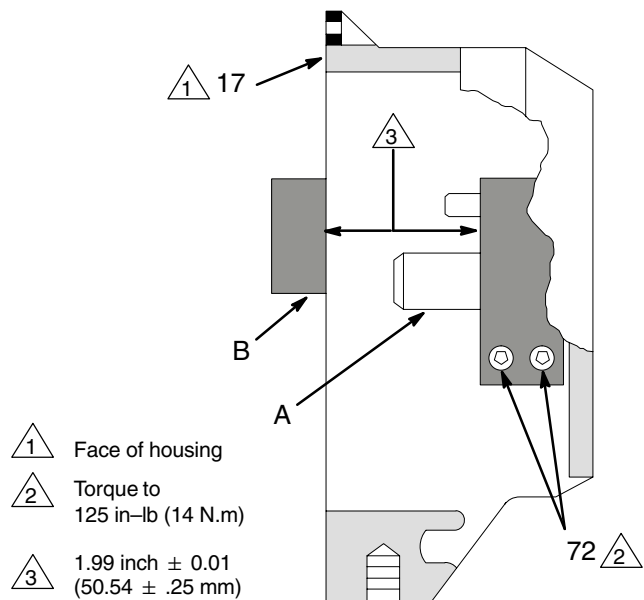

Fig. 27 0049

- F From Engine
- G To Field
- H Black
- J White
- K Green w/red cover
- L Red

VIEW FROM UNDER ENGINE MOUNTING PLATE

Fig. 29



SIDE CUTAWAY VIEW OF CLUTCH HOUSING

Fig. 28 0050

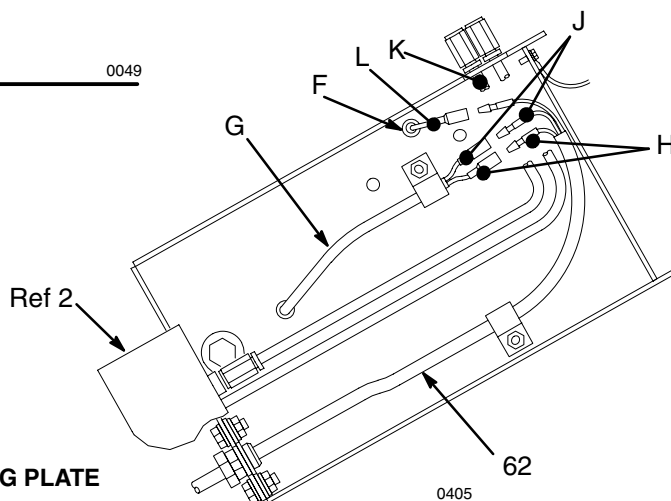

0405

# Reassembly



**NOTE:** Refer to Fig. 29 and 30 for Steps 5 to 7.

5. Place the **engine (45)** on the cart. Align the mounting holes. Guide the engine wire (A) and wiring harness (69) through the mounting plate grommets (8). Install the screws (42) and nuts (43) and torque to 15 ft-lb (20 N.m). Install the capscrews (5), lockwashers (6) and washer (7) from under the engine mounting plate to secure the clutch housing (17). Connect the like-colored wires as shown in Fig. 29.
6. Be sure the face of the **rotor (9a)** and the field (10) is free of all oil and contaminants. Install the rotor, lockwashers (70) and capscrews (72). Torque the capscrews to 7 ft-lb (9.5 N.m).

After installing the rotor (4b), check the clearance between the outside diameter of the rotor and the inside diameter of the field. The clearance must be at least 0.010 in. (0.25 mm) all the way around. Use shim stock or feeler gauge. If necessary, loosen the setscrews (12) and reposition the field. Tighten the setscrews evenly to 27 in-lb (3.2 N.m).

Be sure the face of the **armature (9b)** is clean. Assemble the armature to the shaft in the pinion housing (C). A retaining ring located within the armature makes it difficult to assemble these parts. For the best results, first engage a few splines of both parts, then use a screwdriver to gently push the retaining ring into the armature, and then engage the remaining splines. Push the armature onto the shaft until it contacts the ring.

7. Assemble the **drive/pinion housing (C)** to the clutch housing, using the capscrews (3) and lockwashers (2).
8. Connect the cord set (62) to the pressure control.

- 1  Torque to 7 ft-lb (9.5 N.m)
- 2  Faces must be clean
- 3  Torque to 15 ft-lb (20.4 N.m)

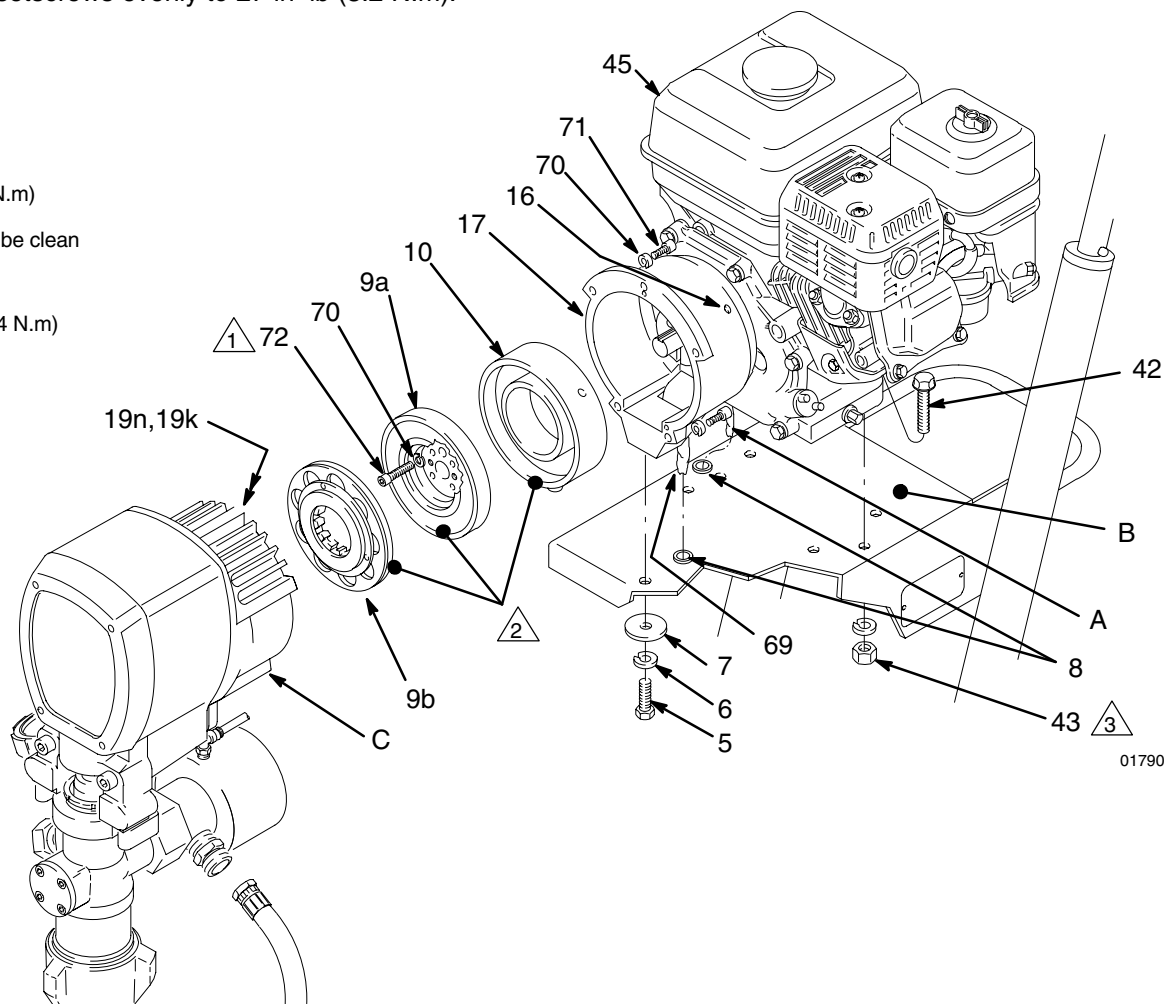

Fig. 30

# Parts - Displacement Pump

## Model 235706, Series A

Includes items 201227

Ref No.	Part No.	Description	Qty
201	188437	PISTON ROD	1
202	187068	PACKING NUT	1
203	188560*	V-PACKING, poly	2
204	187939*	GLAND, male	1
205	188557*	O-RING	2
206	187934	PISTON HOUSING	1
207	188559*	O-RING, fluoroelastomer®	1
208	188434*	NUT	1
209	188432*	GLAND, male	1
210	188561*	V-PACKING, poly	2
211	188433*	GLAND, female	1
212	188627	BACKUP WASHER, nylon	1
213	235165	PISTON SEAT	1
214	187929	LUG NUT	1
215	235732	INTAKE HOUSING	1
216	102973*	BALL, intake, 0.125 inch ID	1
217	187064	BALL GUIDE	1
218	188558*	U-CUP SEAL, poly/fluoroelastomer®	1
219	187072*	V-PACKING, poly	3
220	102972*	BALL, piston; 0.875 inch ID	1
221	187066	CYLINDER	1
222	111729	SCREW, No. 10-32 x 5/8 inch	4
223	188554*	O-RING	1
224	188629	PLUG	1
225	187071*	V-PACKING, poly	3
226	187070*	GLAND, female	1
227	187933	HOUSING, outlet	1
228	183210	PIN	1
232	235962	SEAL, foot valve	1

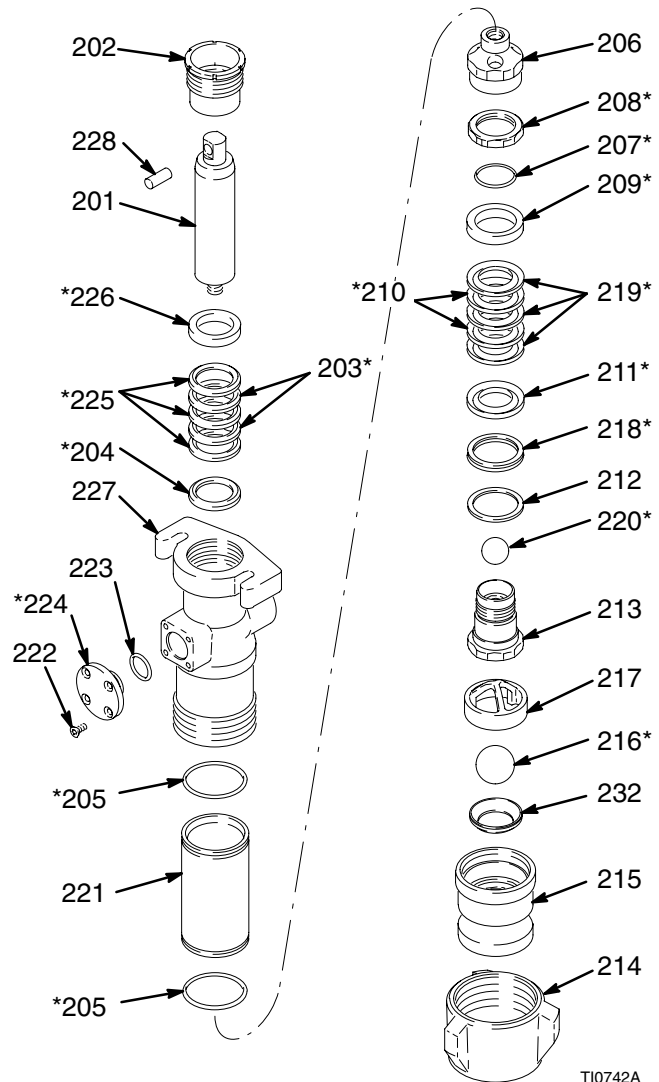

\* These parts are also included in **Repair Kit 235186**, which may be purchased separately. Keep a kit on hand to reduce down time. The kit also includes one 8-cup packing, 111829, for the pressure drain valve.

TI0742A

# Parts - Pinion Assembly

## Ref No. 19

### Pinion Housing

Includes items 19a to 19f

Ref No.	Part No.	Description	Qty	Ref No.	Part No.	Description	Qty
19a	221032	PINION SHAFT ASSEMBLY Includes items 19b to 19f	1	<b>NOTE:</b> Items 19h to 19p are not included in a kit. Order them separately as needed.			
19b	183395	.SHAFT, pinion	1	19h	108692	BEARING, needle, roller	1
19c	108797	.BEARING, ball	1	19j	107088	BEARING, needle, needle	1
19d	108798	.BEARING, ball	1	19k	100069	BALL, sst	1
19e	108796	.RING, retaining, external	1	19m	108799	RING, retaining, internal	1
19f	183396	.HUB, armature	1	19n	105489	PIN, dowel	2
				19p	194311	HOUSING, pinion	1

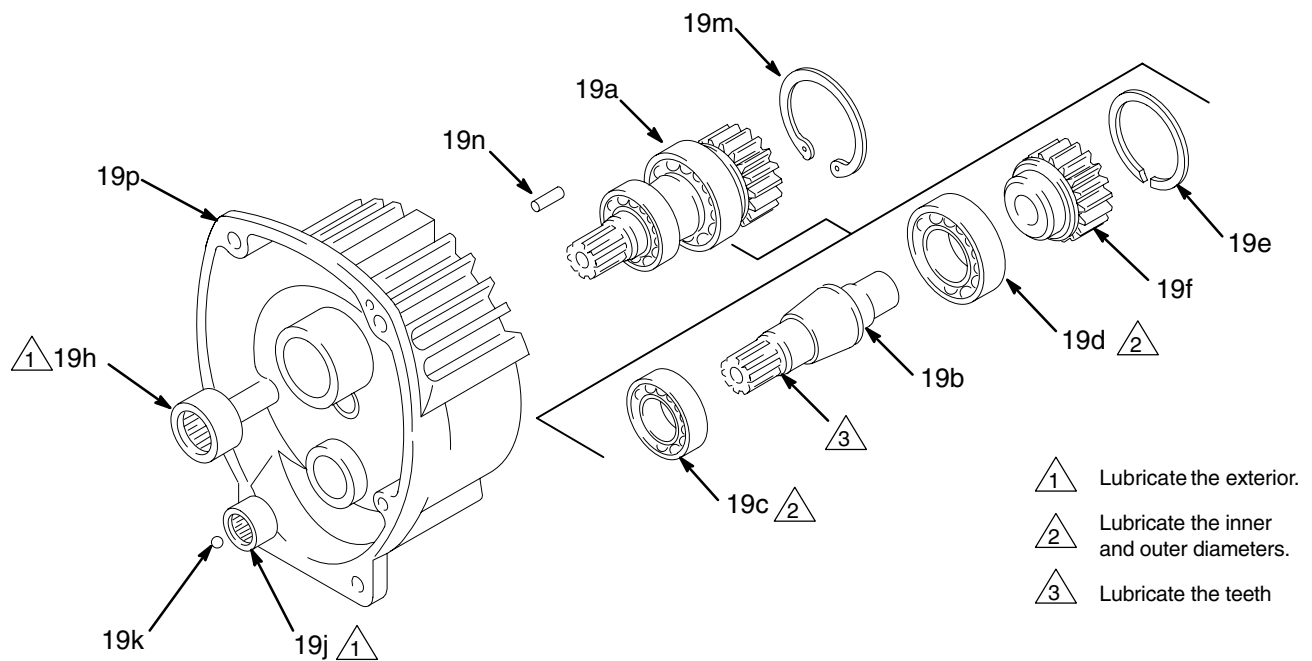

0042

# Parts - Sprayer





## Model 231300

Includes all items listed on pages 34 to 37.

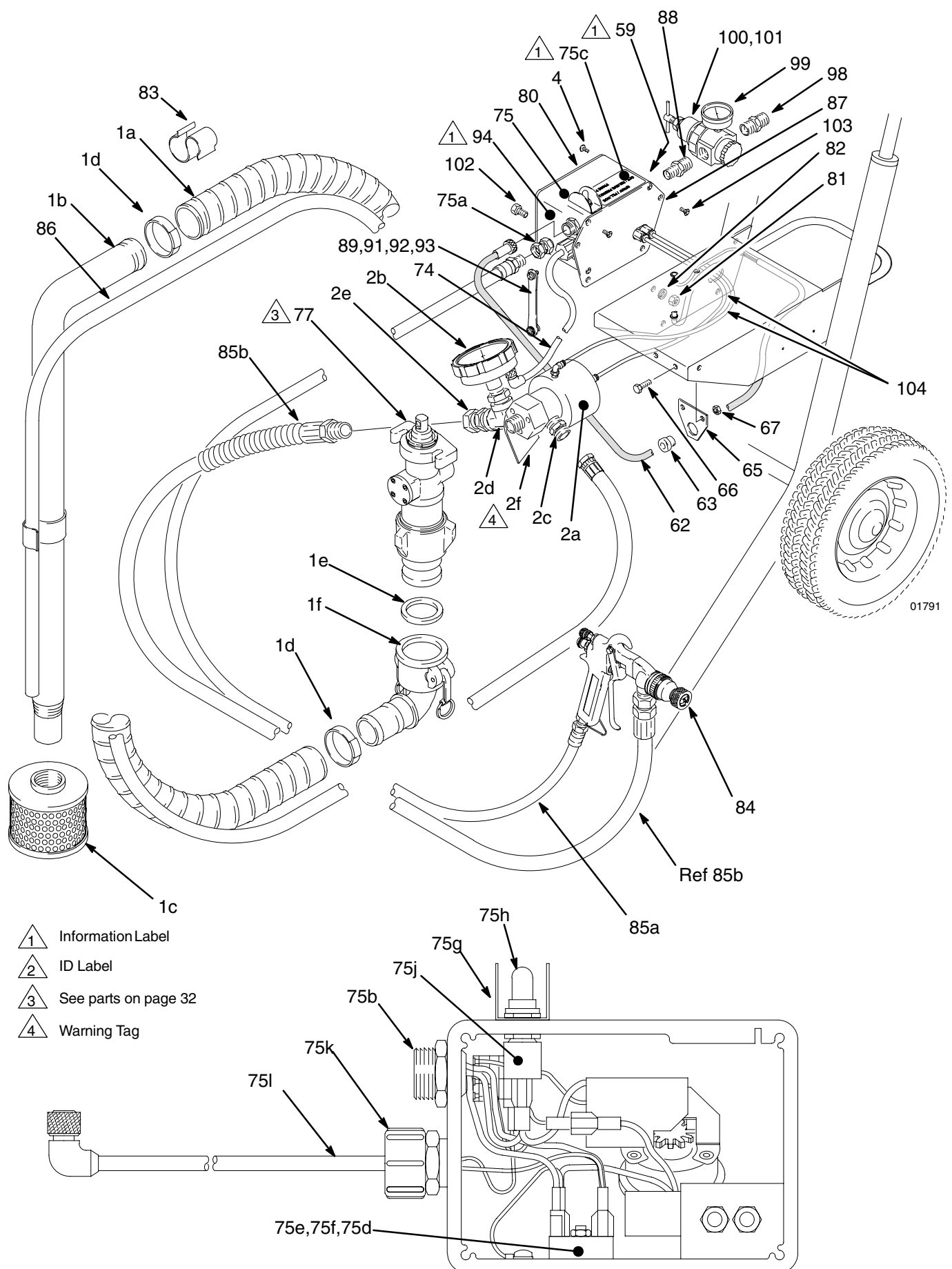
Ref No.	Part No.	Description	Qty	Ref No.	Part No.	Description	Qty
1	224442	55 GALLON SUCTION KIT <i>Includes items 1a to 1f</i>	1	75j	109551	. ON/OFF SWITCH	1
1a	187123	HOSE, 2 inch ID	1	75k	109550	. STRAIN RELIEF BUSHING	1
1b	187131	SUCTION TUBE	1	75l	111942	. POWER CORD	1
1c	187119	STRAINER	1	77	235706	DISPLACEMENT PUMP <i>See parts on page 32</i>	1
1d		CLAMP ( <i>clamp supplied with sprayer requires special tool</i> )	2	80	185002	PRESSURE CONTROL COVER	1
1e	111340	GASKET	1	81	100188	NUT, heavy hex, 5/16–18 unc–2a	4
1f	111338	COUPLER, 90°, quick disconnect	1	82	100214	LOCKWASHER, 5/16 inch	4
2	235467	AUTOMATIC PRESSURE DRAIN VALVE <i>Includes replaceable items 2a to 2f</i>	1	83	188509	SPRING CLIP	2
2a	235667	.BARE DRAIN VALVE	1	84	235490	GUN <i>See manual 308274 for parts</i>	1
2b	111838	.GAUGE	1	85	235737	HOSE SET, 50 ft (15 m) long <i>Includes items 85a and 85b</i>	1
2c	111834	.NIPPLE	1	85a	235487	. AIR, 1/2 inch ID, cpld 3/8 npt(m) x 3/8 npsm (f) swivel	1
2d	111337	.TEE	1	85b	235670	. FLUID, 3/4 inch ID, spring guard one end, cpld 3/4 nptf(m) x 3/4 npsm(f) swivel	1
2e	157785	.ADAPTER	1	86	235738	DRAIN HOSE	1
2f	188359	.WARNING TAG	1	87	188507	MOUNTING PLATE	4
4	110885	SCREW, No. 10–24 x 3/8 inch	4	88	188577	NIPPLE	1
59	188564	LABEL, identification	1	89	109563	CAP	1
62	224538	CORD SET	1	91	109560	SCREW, 1/4–20 x 1/4 inch	1
63	111348	BUSHING, strain relief	1	92	801023	WASHER, 5/16 inch	1
65	187182	BRACKET, power cord	1	93	188548	STRAP	1
66	110963	SCREW, serrated flange, hex hd, 5/16–18 x 3/4 inch	6	94	188634	LABEL, air outlet	1
67	110996	NUT, flanged, hex hd	2	98	158491	NIPPLE, 1/2 npt	1
74	224538	CORD	1	99	101689	GAUGE, air, 0–200 psi (0–1.3 MPa, 0–13 bar)	1
75	235740	PRESSURE CONTROL <i>Includes replaceable items 75a to 75l</i>	1	100	104267	REGULATOR, air, 0–125 psi (0–0.8 MPa, 0–8 bar)	1
75a	235728	. SWIVEL UNION, 3/8 npt(m) x 3/8 npsm(f) swivel	1	101	100721	PLUG, 1/4 nptf <i>not shown, install in bottom of regulator (100)</i>	1
75b	188577	. NIPPLE, 1/2 to 3/8 npt	1	102	101344	LOCKWASHER	4
75c	188633	. LABEL, switch	1	103	106078	SCREW	4
75d	111936	. BRIDGE	1	104	235961	HOSE KIT	1
75e	109557	. SCREW, 10–24 x 7/8 inch	1				
75f	100179	. WASHER	1				
75g	109565	. GUARD	1				
75h	109566	. BOOT	1				

# Parts - Sprayer



-  Information Label
-  ID Label
-  See parts on page 32
-  Warning Tag

01828

# Parts - Drive

## USE ONLY GENUINE GRACO PARTS AND ACCESSORIES

### Model 231300, Series A

Includes all items listed on pages 34 to 37.

Items on this page are shown on page 37

Ref No.	Part No.	Description	Qty	Ref No.	Part No.	Description	Qty
5	100469	CAPSCREW, hex hd; 3/8-16 x 3/4 inch	1	33	111590	BUTTON, snap	2
6	100133	LOCKWASHER, 3/8 inch	1	34	224002	CART	1
7	108851	WASHER, plain, 3/8 inch	1	35	108795	SCREW, mach, pnh, 10-32 x 5/16 inch	4
8	108805	BUSHING, snap	2	36	187604	BUSHING	2
9	221031	CLUTCH ASSEMBLY <i>Includes items 9a, 9b</i>	1	37	220918	HANDLE w/hose rack	1
9a		.ROTOR	1	38▲	181867	LABEL, WARNING <i>on engine</i>	1
9b		.ARMATURE	1	39▲	185953	LABEL, DANGER <i>on drive housing</i>	1
10	183400	FIELD	1	40	108850	SCREW, mach, filh; 8-32 x 1-1/4 inch	4
11	108842	CAPSCREW, sch, 5/16-24 x 3/4 inch	4	41	108849	CAPSCREW, hex socket head, 1/4-20 x 3 inch	2
12	100214	LOCKWASHER, 5/16 inch	4	42	110837	SCREW, serrated flange, hex hd, 5/16-18 x 1-1/2 inch	2
13	108800	PIN, dowel; 5/16 x 1 inch	1	43	110838	LOCKNUT	2
14	183401	KEY, shaft	1	44	108794	PLUG, tubing	2
15	183517	CLAMP, mounting, rotor	1	45	108802	ENGINE, gasoline, 5 HP	1
16	108801	SETSCREW, 1/4-20 x 5/16 inch	4	48	110616	CAPSCREW, socket head, 3/8-16 x 1-1/2 inch (special)	4
17	183397	HOUSING, clutch	1	49	106115	LOCKWASHER, 3/8 inch	4
19	241286	PINION HOUSING See parts on page 31	1	56	188563	LABEL, identification	1
20	241291	DRIVE HOUSING <i>Includes items 20a - 20d</i>	1	57	108860	SCREW, mach, slotted, bdgh 8-32 x 1/4 inch	2
20a	106227	.WASHER, bronze colored	1	60	187111	SCREW, quick disconnect	2
20b	183209	.WASHER, silver colored	1	61	183169	SPRING, retaining	1
20c	100069	.BALL	1	64	108868	CLAMP, wire	2
20d	110293	.TUBE, grease ( <i>not shown</i> )	1	68▲	187240	LABEL, warning	1
21	183168	COVER, drive housing	1	69	220980	ELECTRICAL HARNESS	1
22	220640	CONNECTING ROD	1	70	105510	LOCKWASHER, 1/4 inch	17
23	224484	BEARING HOUSING	1	71	100644	CAPSCREW, hex socket head, 1/4-20 x 3/4 inch	9
24	101242	RETAINING RING, ext	2	72	108803	CAPSCREW, hex socket head, 1/4-28 x 1 inch	6
25	154636	WASHER	2	73	220919	GEAR REDUCER	1
26	179811	WHEEL	2				
27	104811	HUBCAP	2				
28	108068	PIN, spring, straight, 3/16 inch x 1.25 inch	2				
29	183350	WASHER	2				
31	112798	SCREW, mach hex washer hd, No. 8-32 x 3/8 inch	1				
32	237686	GROUNDING CLAMP w/25 foot (7.6 m) wire	1				

▲ Replacement Danger and Warning labels, tags and cards are available at no cost.



# Parts - Drive

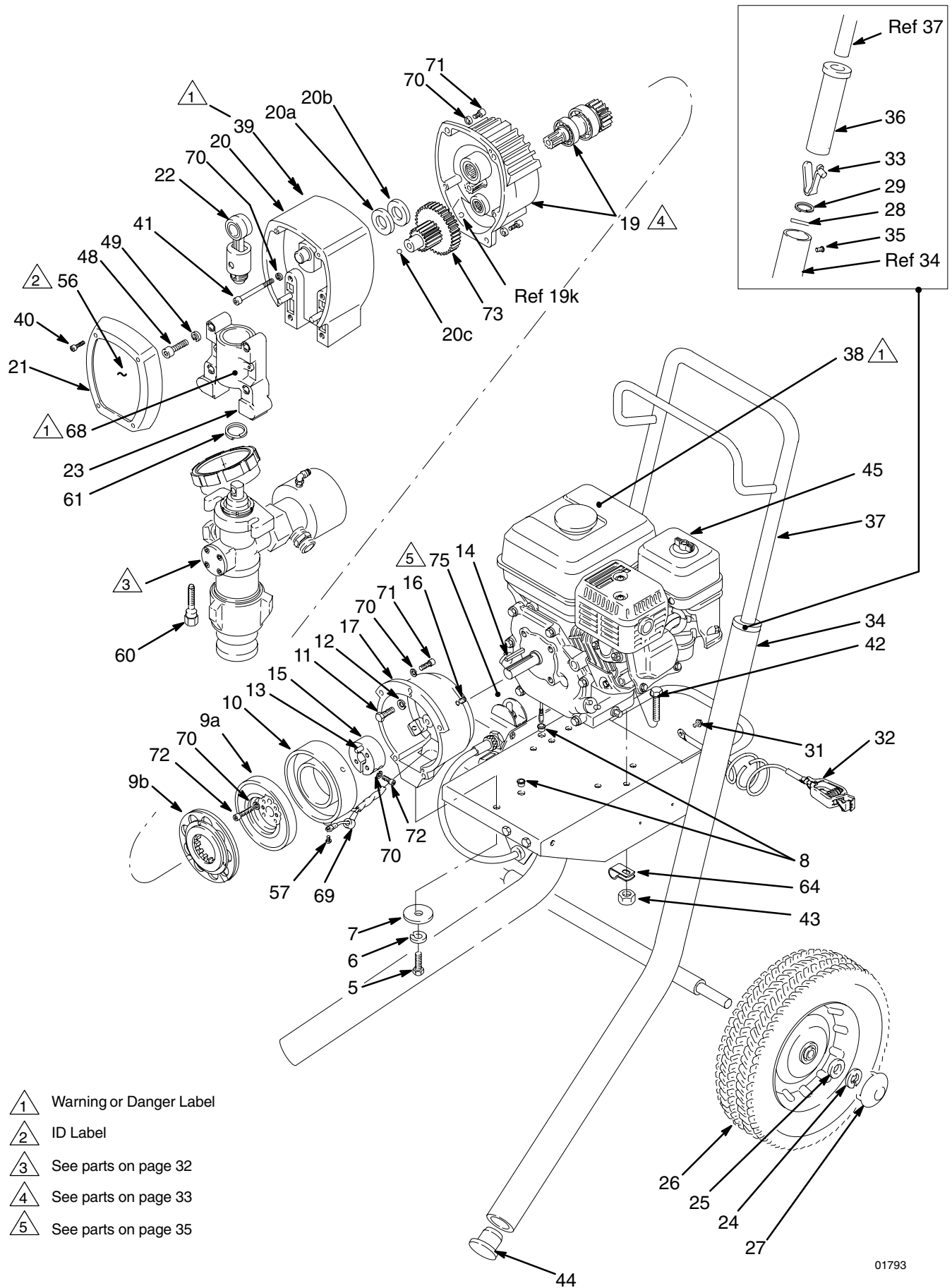

- 1 Warning or Danger Label
- 2 ID Label
- 3 See parts on page 32
- 4 See parts on page 33
- 5 See parts on page 35

01793

# Accessories

## USE ONLY GENUINE GRACO PARTS AND ACCESSORIES

**Displacement Pump Repair Kit** 235186  
See contents on page 32. Repair instructions are included with the kit.

**Air And Material Hose Kit** 235739  
*Fluid: 750 psi (5.18 MPa, 51.7 bar)*  
*Max. Working Pressure*  
*Air: 300 psi (2.07 MPa, 20.7 bar)*  
*Max. Working Pressure*

50 ft (15.2 m) hoses to supplement the 50 ft (15.2 m) hose kit supplied with the sprayer. Use up to three more hose kits. DO NOT use this kit at the sprayer outlet as it does not have a spring guard on the material hose.

**GM3012 High Pressure Displacement Pump, Pressure Control, And Filter Kit** 224524  
*3000 psi (21.0 MPa, 210 bar)*  
*Maximum Working Pressure*  
*Up to 1.2 gpm*

Quickly convert the GM1030 TexSpray sprayer to an airless sprayer to spray primer, sealer, smooth elastomerics as well as architectural paints, acrylics, urethanes and bonding adhesives at up to 1.25 gpm (4.75 lpm) with 0.035 inch maximum size spray tip at 3000 psi (21.0 MPa, 210 bar) Maximum Working Pressure. This accessory includes a high pressure pump, fluid filter, optional filter screen, drain valve and pressure control.

The system requires an airless spray gun and tip guard and an airless spray hose with spring guards on both ends. These accessories must be rated for at least 3000 psi (21.0 MPa, 210 bar) working pressure.

**2 Gpm Displacement Pump** 235965  
*1000 psi (7.0 MPa, 70 bar)*  
*Maximum Working Pressure*

This accessory kit directly replaces the standard TexSpray 3 gpm pump. Use it when spraying smooth and fine textures where lower volume is important for better control. Operates in the 1/4 to 2 gpm range (Not shown.)

**High Pressure Spray Hoses**  
*3000 psi (21.0 MPa, 210 bar)*  
*Maximum Working Pressure*

**214705** 3/8" ID, cpld 3/8 npt(m); 50 ft (15 m), spring guards both ends

**223541** 1/4" ID, cpld 1/4 npsm(f); 50 ft (15 m), spring guards both ends

**214701** 1/4" ID, cpld 1/4 npsm(f); 3 ft (0.9 m), spring guards both ends

### Adapters

**157705** Union, 1/4 npt(m) x 3/8 npsm(f)

**150287** Adapter, 1/4 npt(m) x 3/8 npt(f)

**156173** Union, 3/8 npt(f) x 3/8 npsm(f)

**Optional Flow Restrictor** 190109  
This accessory (E) restricts the flow of fluid to the gun when using thin materials. Install as shown in Fig. 3.

**Air Cylinder Repair Kit** 244111  
This repair kit includes wear parts for the air cylinder.

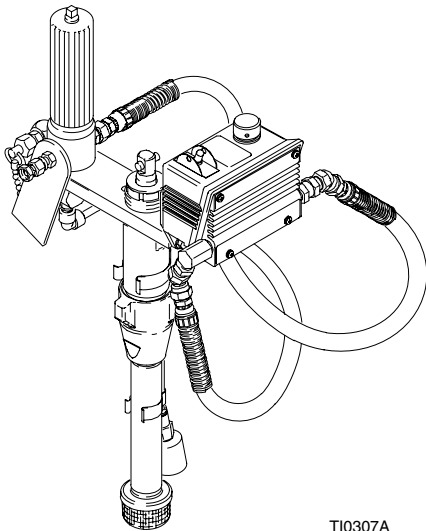

TI0307A

# Technical Data

Honda GX160 Engine  
Power Rating @ 3600 rpm  
ANSI ..... 5.5 Horsepower  
DIN 6270/DIN 6271  
NA ..... 2.9 Kw–4.0 Ps  
NB ..... 3.6 Kw–4.9 Ps  
Maximum Working Pressure ..... 1000 psi  
(7.0 MPa, 70 bar)  
Cycles/gallon (liter) ..... 42 (11)  
Maximum Delivery ..... 3 gpm (11 liter/min)  
Fuel Tank Capacity ..... 0.95 gallon (3.7 liter)  
Pump Inlet Size ..... 2 inch quick disconnect  
Fluid Outlet Size ..... 3/4 npsm(f)  
Wetted Parts  
*Displacement Pump* . . . . . Nickle-plated carbon steel,  
Stainless steel, Chrome-plated stainless steel,  
Poly, Tungsten carbide, Viton®

## Sound Data

### Sprayer:

Sound Pressure Level ..... 97dB(A)\*

Sound Power Level ..... 105dB(A)\*

\*Measured readings at 1 m, normal load.

### Gun:

Sound Pressure Level ..... 96dB(A)\*\*

Sound Power Level ..... 104dB(A)\*\*

\*\*Measured while spraying simulated acoustical texture under typical conditions as specified by the material manufacturer.

Viton is a registered trademark of the DuPont Co.

# Dimensions

Weight (dry, without packaging) . . . 150 pound (68 kg)  
Height ..... 32 inch (813 mm)  
Length ..... 30 inch (762 mm)  
Width ..... 23 inch (584 mm)

# Graco Phone Number

**TO PLACE AN ORDER**, contact your Graco distributor, or call this number to identify the distributor closest to you: **1-800-690-2894 Toll Free**

# The Graco Warranty and Disclaimers

Graco warrants all equipment referenced in this document which is manufactured by Graco and bearing its name to be free from defects in material and workmanship on the date of sale to the original purchaser for use. With the exception of any special, extended, or limited warranty published by Graco, Graco will, for a period of twelve months from the date of sale, repair or replace any part of the equipment determined by Graco to be defective. This warranty applies only when the equipment is installed, operated and maintained in accordance with Graco's written recommendations.

This warranty does not cover, and Graco shall not be liable for general wear and tear, or any malfunction, damage or wear caused by faulty installation, misapplication, abrasion, corrosion, inadequate or improper maintenance, negligence, accident, tampering, or substitution of non-Graco component parts. Nor shall Graco be liable for malfunction, damage or wear caused by the incompatibility of Graco equipment with structures, accessories, equipment or materials not supplied by Graco, or the improper design, manufacture, installation, operation or maintenance of structures, accessories, equipment or materials not supplied by Graco.

This warranty is conditioned upon the prepaid return of the equipment claimed to be defective to an authorized Graco distributor for verification of the claimed defect. If the claimed defect is verified, Graco will repair or replace free of charge any defective parts. The equipment will be returned to the original purchaser transportation prepaid. If inspection of the equipment does not disclose any defect in material or workmanship, repairs will be made at a reasonable charge, which charges may include the costs of parts, labor, and transportation.

**THIS WARRANTY IS EXCLUSIVE, AND IS IN LIEU OF ANY OTHER WARRANTIES, EXPRESS OR IMPLIED, INCLUDING BUT NOT LIMITED TO WARRANTY OF MERCHANTABILITY OR WARRANTY OF FITNESS FOR A PARTICULAR PURPOSE.**

Graco's sole obligation and buyer's sole remedy for any breach of warranty shall be as set forth above. The buyer agrees that no other remedy (including, but not limited to, incidental or consequential damages for lost profits, lost sales, injury to person or property, or any other incidental or consequential loss) shall be available. Any action for breach of warranty must be brought within two (2) years of the date of sale.

**GRACO MAKES NO WARRANTY, AND DISCLAIMS ALL IMPLIED WARRANTIES OF MERCHANTABILITY AND FITNESS FOR A PARTICULAR PURPOSE, IN CONNECTION WITH ACCESSORIES, EQUIPMENT, MATERIALS OR COMPONENTS SOLD BUT NOT MANUFACTURED BY GRACO.** These items sold, but not manufactured by Graco (such as electric motors, switches, hose, etc.), are subject to the warranty, if any, of their manufacturer. Graco will provide purchaser with reasonable assistance in making any claim for breach of these warranties.

In no event will Graco be liable for indirect, incidental, special or consequential damages resulting from Graco supplying equipment hereunder, or the furnishing, performance, or use of any products or other goods sold hereto, whether due to a breach of contract, breach of warranty, the negligence of Graco, or otherwise.

## **FOR GRACO CANADA CUSTOMERS**

The parties acknowledge that they have required that the present document, as well as all documents, notices and legal proceedings entered into, given or instituted pursuant hereto or relating directly or indirectly hereto, be drawn up in English. Les parties reconnaissent avoir convenu que la rédaction du présente document sera en Anglais, ainsi que tous documents, avis et procédures judiciaires exécutés, donnés ou intentés à la suite de ou en rapport, directement ou indirectement, avec les procédures concernées.

*All written and visual data contained in this document reflects the latest product information available at the time of publication.  
Graco reserves the right to make changes at any time without notice.*

This manual contains English mm 309269

**Sales Offices:** Minneapolis, Detroit

**International Offices:** Belgium, Korea, Hong Kong, Japan

**GRACO INC. P.O. BOX 1441 MINNEAPOLIS, MN 55440-1441**

**<http://www.graco.com>**

Written in USA 2/1993, Rev 10/200